



TRESTON
GROUP



Ergonomic
WORKSPACES

PRODUCT CATALOGUE 2014-2015







About us

Dedicated to human workspace	4
Ergonomics in our workspaces	8
Decorating with colour	10
ESD protection	12



Workbenches and accessories

WB	14
Concept	18
MultiLine and FlexFlow	26
TP and TPH	38
	40



Lighting

Lighting ergonomics	50
Magnifying light ZL3	52
Hillite, ProLite, Satelliite and Task light	53
Overlight OL 254 and sidelight SL224	54
	55

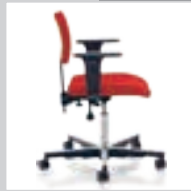

Chairs

X-chairs	56
Saddle chairs	59
Foot rests	60
Accessories for chairs	60
	61



Trolleys

Universal trolley WTR	62	Adjustable trolley TRTA	70
Multi trolley	66	Mobile workstation MLC	72
Basic trolley	67	Trolleys for additional workspace	73



Drawer units

Light steel cabinets LMC	74
Drawer units 30 and 35	79
Drawer unit 45	79
Drawer unit 75	80
	82



Shelves and cabinets

Storage system and cabinets	84
Industrial cabinets	88
Shelf cabinets and light shelf cabinets	90
Small parts shelving	94
	95



Industrial screens

Industrial office screen system	96
Perforated industrial screens	99
	101



Perforated panels

Perforated panels	102
Panel hooks	105
	106





For a Better Work Environment

Dedicated to human workspace



Treston Group is among the world's leading suppliers of industrial furniture and workstations.

Our workstation design and implementation process always begins with the person performing the work. In this way, we pay close attention to ergonomics, functionality and efficiency.

The four cornerstones of our operations are customer-focus, reliability, high quality and continuity. We listen to your needs and reliably deliver high-quality and durable solutions, which last from one generation to the next, thanks to our optimal design.

Our own sales network and distributors dedicated to our products provide worldwide assistance and service in support of Treston Group products.





Industrial furniture and workstations for different working environments

Treston Group's product range is divided into three categories, a separate catalogue is available for each category. Please contact our agents or email us at: sales@trestongroup.com to get your own copy.

Ergonomic workstations

The seamless efficiency of material flows is emphasised in assembly workstations.

Process changes in production or operations require reconfigurable workstations that take account of individual ergonomics requirements. Our modular product solutions allow you to react to new situations and the resulting needs in an agile manner, enabling smooth, continuous operations. Thanks to our extensive selection of accessories, we are able to satisfy even the most individual of needs.

Our own design and years of experience enable us to customise each solution to best suit its purpose. For the needs of the electronics industry, we make ESD-protected workstations, suitable for furnishing EPAs. These workstations are also highly suitable for precision mechanics and mechanical engineering.

Distinctive workshops

Our workshop drawer cabinets, tool panels and workbenches are designed to withstand heavy loads and strenuous use in workshops, repair shops and industrial environments.

The long lifetime of our furniture guarantees productivity and a satisfied user. Our workshop furniture is also well known in teaching environments.

Swift in-house logistics

Treston storage furniture encompasses both ease of use and design. Our selection provides solutions to a surprisingly broad range of storage challenges, regardless of the users and sector.

Our plastic storage drawers are durable and easy to clean, and can be customised into a complete storage system if necessary. Our product range also includes various stand and trolley solutions, for the more efficient use of storage space and easier movement of stored goods.

We also have storage furniture for environments that require ESD protection. In addition, some of our storage solutions are moulded from reprocessed plastic.

Packaging and shipping departments are often found at the end of production processes. Their logistic efficiency can be easily improved through sensible workstation design.

A great deal of manual labour and quality assurance are typical of the packaging stage, in both individual stations and line solutions. Our solution for the needs of these segments often builds on the idea of "more for less".

When accessories are located and positioned according to LEAN principles, you can significantly speed up throughput and reduce work strain. Cutters, pens, knives, rubbish bins and displays can be positioned in a way that provides the user with the best possible ergonomics, while also ensuring a free and uncluttered workspace.



Workstations for every need

Optimising workstation functionality may prove difficult without well-chosen accessories that increase usability. When a workstation is well-planned and well-equipped, workflow becomes easier and more efficient, improving ergonomics and making it easier to keep tools in place.

Modular means adaptable

Our world keeps changing at an ever-increasing pace. Until recently, products could be manufactured the same way for decades, but now we must be prepared to make changes to our work practices at a much faster rate. In order to revise the production process to meet new requirements, an extremely flexible and adaptable workstation system is essential. Our system is designed particularly with this in mind. The same basic units, equipped with accessories that meet your needs, offer a wide range of applications.

Customised for your application and your operator

The purpose of a workstation determines its basic requirements and accessories. The needs and requirements may change considerably from one employee to another, but we understand that no two people are alike. When a workstation is equipped for and adjusted to an individual's needs, each phase of the production process can be completed without delay, with accuracy and with maximum comfort.

Treston Group offers a wide range of ergonomic workstations to choose from, from those that can be delivered quickly to those that provide versatile options to meet any need.





Ergonomics in our workstations

Costs associated with health and safety problems are an ever increasing concern to all industries. This concern drives industries to seek solutions to provide a healthy, safe and productive working environment. **Designing a workplace with ergonomics in mind improves the employees' wellbeing which in turn improves productivity.**

The modular design of Treston Group workstations enables proper ergonomics. With a wide range of accessories and adjustments we can provide customers with a customized solution using standard components. **Modularity and accessories are individually adjustable according to the task and operator requirements.** The

aim is to create an uncluttered workstation and utilise the available workspace as efficiently as possible.

Treston Group's workstations and accessories can be adjusted for operators of different heights working with left or right hand. Correctly adjusted workstations decrease stress in the muscles and enable productive work throughout the shift.

Please do remember that ergonomics is not only adjusting your chair. Real ergonomics has to do with proper lighting, noise absorption, body movements and air quality. More information about lighting ergonomics on page 52.

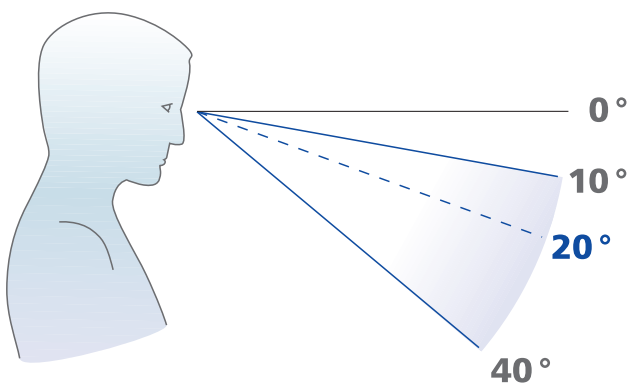

Location of the correct view angle

Focus point should follow these guidelines:

- Continual movement of view should be in 30 degree sector
- Continuous view angle should keep the head in a comfortable position (line of view should be 10 to 40 degrees below the horizontal line)
- Displays should be positioned 20 degrees below the horizontal line



Seated or standup work?

The choice of a seated or standing working position is dependent upon the task to be executed. The height of the work surface is determined by such factors as size and weight of the part, precision requirement, assembly process, repetitiveness etc.

Height adjustability is especially useful when the size of the products being handled varies or when several people use the same workstation.

When designing the work space for a seated operation leg space requirements must be considered. The recommended space should be at least 80 cm wide and 90 cm deep at floor level. For standing work, the required space is much smaller.

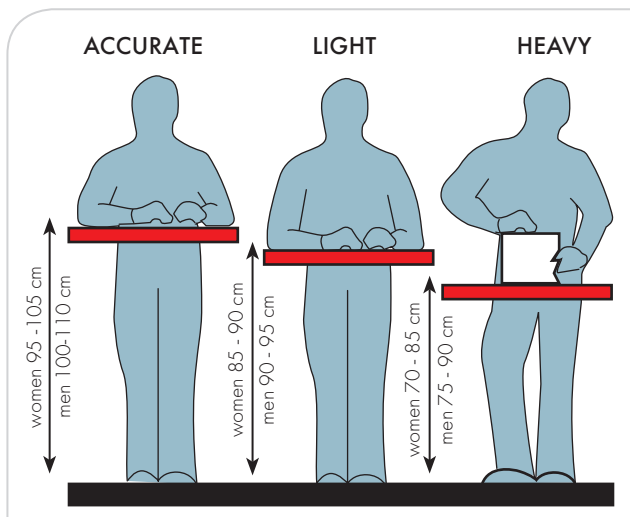

Standing work

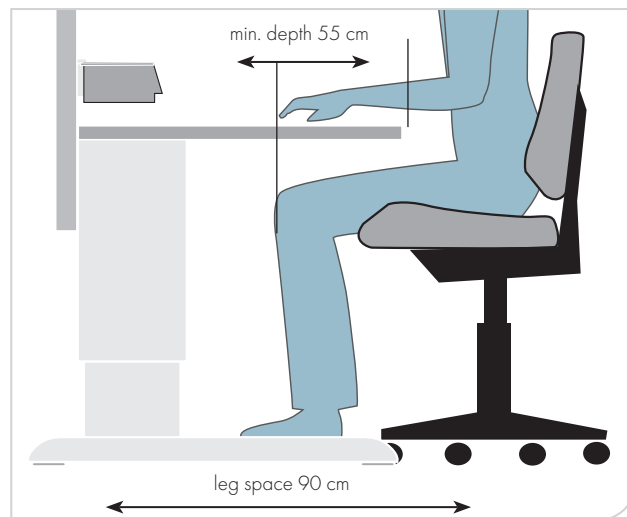

Seated work

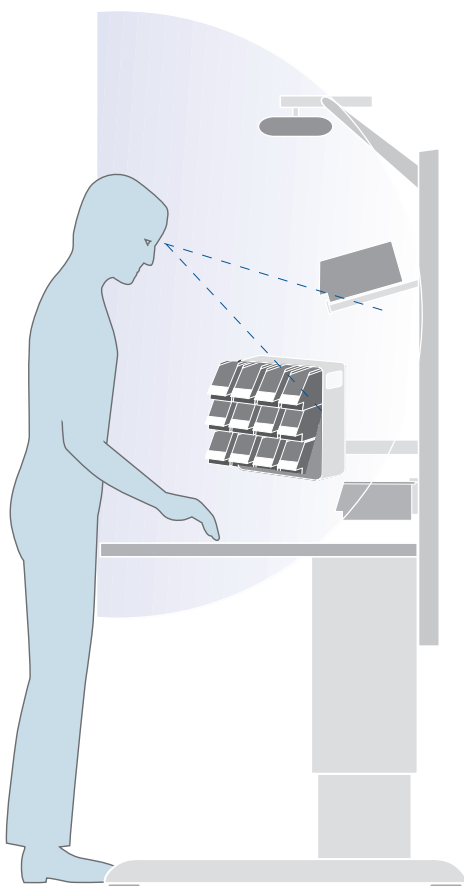

Reaching distances and heights

To improve working postures in assembly work, the most-often used parts should be placed into the optimal horizontal working area within the operator's sight. Avoid overly large or deep workbenches, which can cause improper reach and reduced productivity. Assembly work is most ergonomic when parts are within easy view and reach.

The vertical work area and reach zone can be fine-tuned with accessories. Our height adjustable arms optimize work movements and keep parts or tools within easy access. Operators can work with wrists and arms in optimal posture with shoulders relaxed. Tilted bin rails and shelves keep the wrist in a neutral position when picking parts. The tilt angle also provides easy identification of the parts with the proper viewing angle.

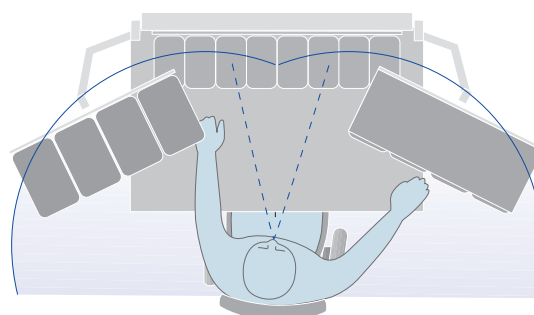

Lighting ergonomics, see page 52.



Decorating with colour

The working environment can also look good and be inspirational. By choosing the colours of your equipment to match your corporate colours, you can reinforce your corporate image whilst creating a pleasant working environment.

Doors, drawers and perforated panels all come in various colours. The combination of different colours creates an interesting effect. Colours can also act as codes or identifiers.





Colour codes

Workbench, cabinet, shelving and drawer frames are all light grey (RAL 7038 or RAL 7035) or dark grey (RAL 7045). Outside of the standard colour range, additional colours are available on request. Please contact our agents or email us at: sales@trestongroup.com.

	Colour code	RAL code	Doors	Drawers	Perforated panels and back panels
Light grey		RAL 7035	STD	A/STD	A/STD
Light grey *	35 & 41	RAL 7038	STD	A/STD	A/STD
Dark grey	45	RAL 7045	A	A	A
Blue	07	RAL 5007	STD	A/STD	STD
Red	25	RAL 3002	A	A	A



The colour code is included in those product codes that are formed with numbers.

It is either at the end, following the hyphen (e.g. 860 804-35), or in the middle (e.g. C 33407000).

***35 is ESD protected light grey, 41 is non-ESD protected light grey. Please remember that ESD protection will result in a slightly darker shade of colour than the given RAL code.**

STD = Standard factory colour, normal warehouse delivery, listed price
A = Factory colour, delivery 15 days from the factory, listed price

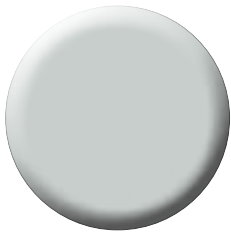

Light grey
RAL 7035

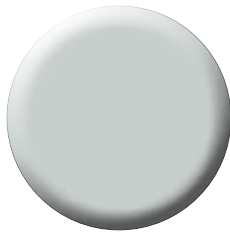

Light grey
RAL 7038

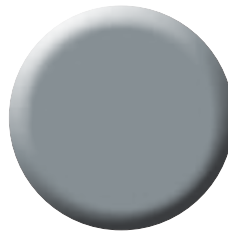

Dark grey
RAL 7045

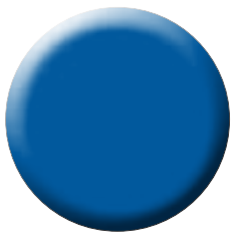

Blue
RAL 5007

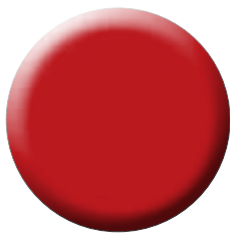

Red
RAL 3002

Printed colours do not give a fully accurate representation of painted colours. Please ask our agent about various samples.



ESD protection guarantees a safe working environment

Particularly in the electronics industry, work is often carried out in an EPA that is protected from static discharge. Protection in this case means effective earthing, which involves both earthing equipment and painting the frame of the ESD workstation with semi-conductive paint.

We have extensive experience in developing, manufacturing and supplying ESD furnishings. All our workstations and related products are supplied with an electrically semi-conductive coat of paint and we supply furnishings, seats and earthing components for ESD-protected workstations. We also build complete production systems equipped with ESD-protection. Our products meet the requirements specified in the IEC 61340-5-1 standard.

Static electricity

The abbreviation ESD stands for Electrostatic Discharge, a process that occurs between two objects of differing electric potential. Normally, electric charges are discharged slowly from objects' surfaces. If the difference in electric potential becomes too great, the electrical current accelerates resulting in a sudden current surge.

An ESD protected area is called an EPA. In an EPA, ESD protection must be observed in all materials, employees' clothing and air humidity. Workstations and employees in an EPA must also be earthed with protective resistance (1 Mohm) to an ESD earth.

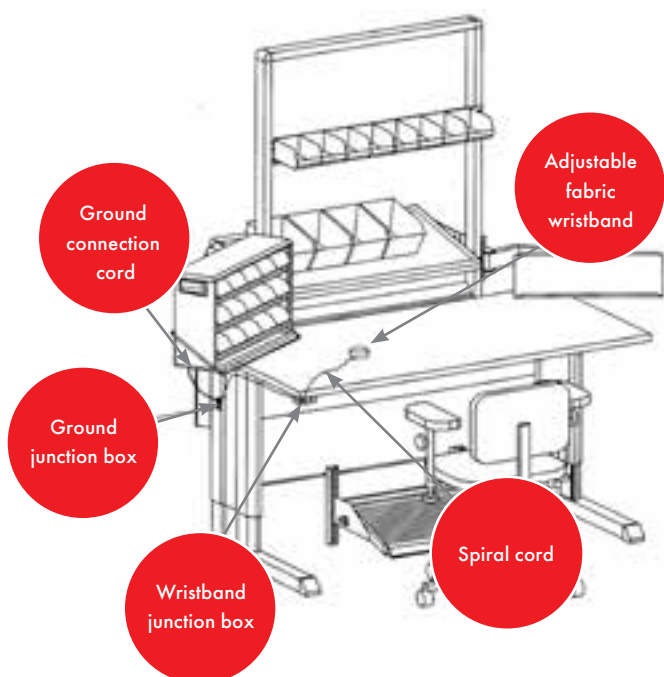



Our standards comply with the highest certification requirements



<p>Quality certification</p> <p>ISO 9001:2008</p>	<p>Environmental Management System certification</p> <p>ISO 14001:2004</p>	<p>Packaging treatment according to EU directives.</p>	<p>IPA Qualification Certificate</p> <p>The Concept workstation is suitable for use in class 10,000 clean rooms in accordance with US Federal Standard 209E.</p>
--	---	---	---



<p>ESD-approval certification</p> <p>Our ESD products fulfill the basic requirements of IEC 61340-5-1.</p>	<p>GS certification for lighting and TP workbench</p>		
---	--	--	--

To obtain a copy of our certificates, please contact info@trestongroup.com.

 All our steel products have a 5-year warranty.



Workbenches and accessories



WB frame



Aluminium upright

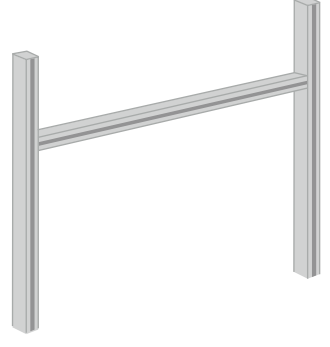

CONCEPT frame



Upright tube

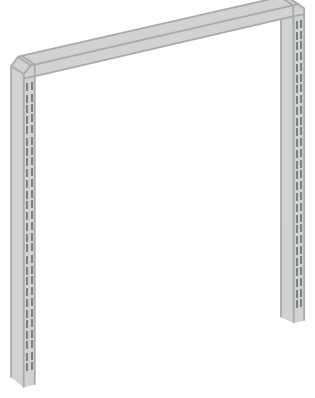

TP / TPH frame



Upright tube

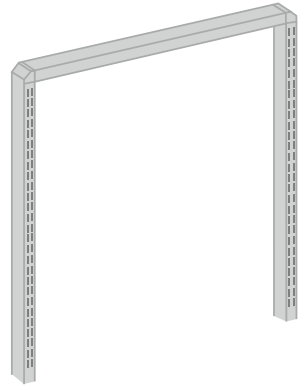

C-profile upright

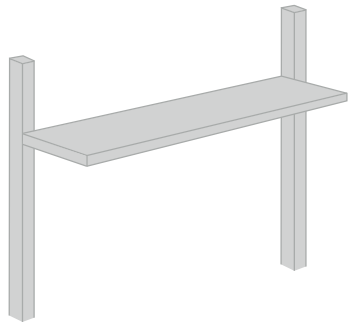



WB workbench, page 18

- Ergonomic and easily adjustable
- Suitable for use in demanding assembly environments
- Adaptable to a large variety of tasks
- Offering a wide range of accessories to meet any need



Concept workbench, page 26

- Ergonomic and highly adaptable to the needs of the user
- Easy to reconfigure thanks to the modular design
- Suitable for heavy loads
- Offering a wide range of accessories to meet any need



TP workbench, page 40

- Steel structure
- A cost-effective option to start with
- Easy to equip with a variety of accessories
- Concept accessories available



TPH workbench, page 45

- Available from stock
- Includes basic elements
- Provides its own selection of accessories





WB workbenches

The WB workbench has been designed for use in demanding assembly environments. The concept is one of simplicity and good ergonomics, allowing each bench to be adapted to a variety of tasks.

Electric motor, manual hand crank or allen key height adjustment cater for standing or seated users, while the generous worktop depth and broad accessory range ensure that everything is within easy reach. Another feature of this new design is the flush bench footprint; benches can be placed side-by-side, back-to-back, or right up against walls with no unnecessary gaps. You can design your workstation to fit your needs perfectly.

Worktop height can be adjusted between 700-1100 mm. The adjustment system in both cases utilises interlocking aluminium profiles, providing a strong, rigid frame. Steel frame parts are epoxy powder coated light grey paint, RAL 7035. Worktops are of 25 mm laminated particle board, adjustable feet are provided for fine levelling.



- Ergonomic and easily adjustable
- Suitable for use in demanding assembly environments
- Adaptable to a large variety of tasks
- Offering a wide range of accessories to meet any need



WB benches examples



WB electric adjustable workbench

Qty	Name	Code
1	Electric adjustable bench	WB815 EL
1	Upright profiles	AL2X150 W
1	Accessory frame	AKK150
1	Shelf	ALH150
1	Support bracket	HSB150
1	Adjustable shelf	ASH70
1	Swivel arm with tray	AKV400
1	Overlight	OL254
1	Power channels	CJK70 SET
2	Bin profile	BP70
1	LCD bracket	MA
1	Light steel cabinet	LMC02



WB allen-key adjustable workbench

Qty	Name	Code
1	Allen-key adjustable bench	WB811
1	Upright profiles	AL2X110 W
1	Shelf	ALH110
1	Support bracket	HSB110
1	Overlight	OL254
1	Adjustable shelf	ASH100
1	Power channels	CJK



WB electric adjustable workbench ESD

Qty	Name	Code
1	Electric adjustable bench	WB815 EL ESD
1	Upright profiles	AL2X150 W
1	Accessory frame	AKK150
1	Shelf	ALH150 ESD
2	Adjustable shelf	ASH70 ESD



WB allen-key adjustable workbench ESD

Qty	Name	Code
1	Allen-key adjustable bench	WB815 ESD
1	Upright profiles	AL2X150 W
1	Accessory frame	AKK150
1	Shelf	ALH150 ESD
1	Support bracket	HSB150
1	Overlight	OL254
1	Adjustable shelf	ASH70 ESD
1	Perforated panel	ARL70
1	Power channels	CJK SET
2	Sidelight	SL224



WB workbench



700-1100 mm



700-1100 mm



700-1100 mm

- Select the height adjustment method: allen-key, electric or crank.
- Stepless height adjustment between 700-1100 mm.
- Select a bench top to suit the frame: laminate or ESD bench top.

WB allen-key adjustable bench

Bench size W x D mm	Max load kg	Code	Code ESD
1073 x 800	250	WB811	WB811 ESD
1500 x 800	250	WB815	WB815 ESD
1800 x 800	250	WB818	WB818 ESD

WB electric adjustable bench

Bench size W x D mm	Max load kg	Code	Code ESD
1073 x 800	200	WB811 EL •	WB811 EL ESD •
1500 x 800	200	WB815 EL	WB 815 EL ESD
1800 x 800	200	WB818 EL	WB818 EL ESD

Adjustment speed using the motor is 19 seconds min. to max.

Cable tidy as standard.

WB crank adjustable bench

Bench size W x D mm	Max load kg	Code	Code ESD
1073 x 800	200	WB811 C •	WB811 C ESD •
1500 x 800	200	WB815 C	WB815 C ESD
1800 x 800	200	WB818 C	WB818 C ESD

Cable tidy as standard.

• = non stock item



CTR trolley

Height adjustment with allen key between 690-990 mm. A lower shelf is integrated. Swivel castors (Ø 100 mm), two of which have brakes. Dimensions 700 x 500 mm, lower shelf 700 x 415 mm.

Size W x D mm	Max load kg	Code	Code ESD
700 x 500	75 / shelf	CTR705	CTR705 ESD

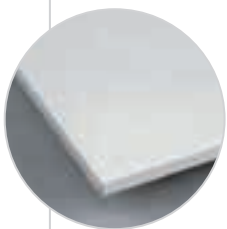

Laminate bench top

- 25 mm low pressure laminate
- Light grey surface
- Plastic edging

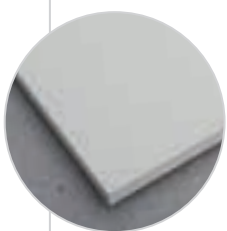

ESD bench top

- Grey laminate surface
- Grey edging
- Thickness 25 mm
- Fixed with screws
- Semi-conductive (ESD)



WB extension benches



1. WB side worktop

This side worktop can be installed on either the right or left hand side of an WB bench to increase the surface area. Installation can be either at the same height, or lower than the main worktop with the brackets provided. Load capacity is 50 kg, and it is suitable for all WB models in the range.

Size W x D mm	Max load kg	Code	Code ESD
800 x 400	50	WB804 ST	WB804 ST ESD

2. WB corner worktop

A corner worktop can be used with two WB benches to create a 90° angle setup. This unit consists of a worktop and all necessary components. It requires no additional leg frames, simply mounting to the standard benches with the brackets provided. Load capacity for this worktop is 50 kg. Suitable for WB EL to order.

Size W x D mm	Max load kg	Code	Code ESD
1154 x 1154	50	WB1212 CT	WB1212 CT ESD



Accessories for WB



Upright profiles AL2X

Upright profiles AL2X

Size W x H mm	Suitable for	Code	Code ESD
1063 x 900	WB811	AL2X110 W	AL2X110 W
1489 x 900	WB815	AL2X150 W	AL2X150 W
1789 x 900	WB818	AL2X180 W	AL2X180 W

Needed for mounting accessories to WB benches. Includes 2 vertical and 1 horizontal profile. With 3 cable clips (CC8).

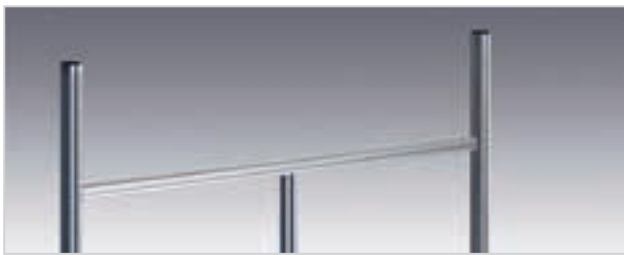

Accessory frame AKK

Accessory frame AKK

Size W x D mm	Suitable for	Code	Code ESD
730 x 540	AL2X150 W AL2X180 W	AKK70	AKK70
690 x 500 + 690 x 500	AL2X150 W	AKK150	AKK150
690 x 500 + 990 x 500	AL2X180 W	AKK180	AKK180

The accessory frame divides the space between the upright profiles into 2 modules. AKK frame includes 1 vertical and 1 horizontal profile. Useable height 500 mm.

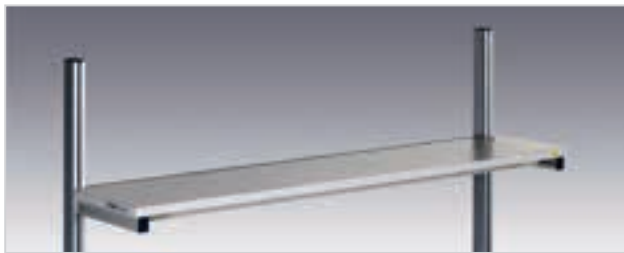

Shelf ALH

Shelf ALH

Size W x D mm	Suitable for	Code	Code ESD
1073 x 310	AL2X110 W, combination AL2X180 W + AKK180	ALH110	ALH110 ESD
1500 x 310	AL2X150 W	ALH150	ALH150 ESD
1800 x 310	AL2X180 W	ALH180	ALH180 ESD

Height adjustable shelf. 25 mm laminated particle board. Load capacity 50 kg. Mount on upright profiles.



Lower shelf AT

Lower shelf AT

Size W x D mm	Max load kg	Suitable for	Code	Code ESD
828 x 400 •	50	WB811	AT110 WB	AT110 WB ESD
1255 x 400 •	50	WB815	AT150 WB	AT150 WB ESD
1555 x 400 •	50	WB818	AT180 WB	AT180 WB ESD

Height adjustable lower shelf, 25 mm laminated particle board. Mount between the legs.

• = non stock item



Backstop LIST

Backstop LIST

Size W x D x H mm	Suitable for	Code
1400 x 52 x 27	ALH150, AT150 WB, AT150 TPH	LIST150
1700 x 52 x 27	ALH180, AT180 WB, AT180 TPH	LIST180

Prevents items from falling off the shelf. Can be fixed on the lower shelf AT or on the shelf ALH.

Divider hoops PDH

Height mm	Suitable for	Code
330	ALH	PDH

Used in combination with shelf ALH. Comes in sets of 5.

Perforated panel ARL

Size W x H mm	Suitable for	Code	Code ESD
668 x 500	AKK70, AKK150	ARL70	ARL70
968 x 500	AKK180	ARL100	ARL100

Mount on accessory frame AKK. The size of the perforation is 9 x 9 mm, center to center 38 mm.

Adjustable shelf ASH

Size W x D mm	Suitable for	Code	Code ESD
660 x 400	AKK70, AKK150, AKK180	ASH70	ASH70 ESD
960 x 400	AKK180	ASH100	ASH100 ESD

Continuous adjustment for depth, height and angle. Shelf of 25 mm laminated particle board. Lipped front edge. Load capacity 35 kg static load. Mount on accessory frame AKK.

Bin profile BP

Length mm	Suitable for	Code	Code ESD
685	AKK 70, AKK150, AKK180	BP70	BP70 ESD
985	AKK180	BP100	BP100 ESD

Aluminium profile for stacking and picking bins. Mount on accessory frame AKK.

Swivel arm with tray AKV

Size W x D mm	Suitable for	Code	Code ESD
460 x 210 (tray)	AL2X upright profiles	AKV400	AKV400 ESD

Lockable, angle adjustable steel tray with swivel radius of 360°. Length of swivel arm 590 mm. Max. load 15 kg.

Component rack EPL

Size W x D x H mm	Suitable for	Shelves number	Code ESD
455 x 200 x 290	AKV	3	EPL12 ESD

Rack with three fixed shelves. Semiconductive epoxy powder coated steel in light grey (RAL 7035). Bins ordered separately, page 36.

Component rack holds:

- 12 stacking bins 1015-4ESD or 12 picking bins 30-1L-4ESD or 6 picking bins 30-2L-4ESD or 6 picking bins 30-23L-4ESD.

Document stand WDA

Size W x H mm	Suitable for	Code	Code ESD
440 x 300	AL2X upright profiles	WDA	WDA ESD

Document stand A3 with swivel arm. Epoxy powder coated steel: light grey. Arm length 220 mm. Tilt 75°.



Divider hoops PDH



Perforated panel ARL



Adjustable shelf ASH



Bin profile BP



Swivel arm with tray AKV



Component rack EPL



Document stand WDA



Bottle holder CH

Bottle holder CH

Size W x D x H mm	Ø mm	Suitable for	Code	Code ESD
110 x 105 x 120	Ø 80	AL2X upright profiles	CH	CH

Practical holder for bottle or cup. Made of black polypropylene.



Recycling material bin PRMB

Recycling material bin PRMB

Size W x D x H mm	Suitable for	Code
530 x 280 x 585	WB benches	PRMB2
530 x 280 x 585	TP benches	PRMB

The 60 ltr bin with steel brackets has a maximum load of 15 kg and can be positioned on either side or rear of the bench.



Tool holder box PPH

Tool holder box PPH

Size W x D x H mm	Suitable for	Code	Code ESD
400 x 300 x 140	WB and TP benches	PPH TXL	PPH TXL
186 x 500 x 182	WB and TP benches	PPH-TL	PPH-TL

PPH TXL with two plastic bins type 3020 and the PPH-TL with one red plastic bin type 1950.



Tool tray PTH

Tool tray PTH

Size W x D mm	Suitable for	Code
1000 x 60	WB benches	PTH100

The tool tray guarantees a clean working space, while tools are close to hand.



Support bracket HSB

Support bracket HSB

Length mm	Suitable for	Code	Code ESD
1073	AL2X110 W	HSB110	HSB110
1500	AL2X150 W	HSB150	HSB150
1800	AL2X180 W	HSB180	HSB180

Support bracket of steel for suspending power tools and lighting units. Mount on upright profiles.



Cable tidy WBCT

Cable tidy WBCT

Size W x D x H mm	Suitable for	Code	Code ESD
948 x 64 x 204 •	WB811	WBCT110	WBCT110
1375 x 64 x 204	WB815	WBCT150	WBCT150
1675 x 64 x 204	WB818	WBCT180	WBCT180

Mount on leg frame. A cable tidy is standard equipment on WB C and WB EL models.

• = non stock item

Cable clip set CC

Set	Suitable for	Code	Code ESD
5 pieces	AL2X upright profiles	CC8	CC8

The cable clip set will hold cables etc. securely and neatly in place along the bench frame. The clips locate in the 8 mm profile slot.



Cable clip set CC

Keyboard shelf WKA

Size W x D mm	Suitable for	Code	Code ESD
500 x 220 (shelf)	AL2X upright profiles	WKA	WKA ESD

Keyboard shelf with swivel arm. Epoxy powder coated steel. Load capacity 15 kg. Arm length 220 mm.



Keyboard shelf WKA

PC stand CPU

Width	Height	Suitable for	Code	Code ESD
130-240 mm	395-500 mm	WB and TP/TPH benches	CPU	CPU
340-460 mm	180-285 mm	SAP, CTR, WTR trolleys		

An adjustable holder for either vertical or horizontal CPU, to mount underneath the table worktop.



PC stand CPU

LCD bracket MH

Max load kg	Suitable for	Code	Code ESD
15	AL2X upright profiles	MH	MH

The quick-release mechanism is equipped with the standard used flat-screen mount 75 x 75 and 100 x 100 for the mounting of all normal flat-screens.



LCD bracket MH

LCD swivel arm MA

Max load kg	Suitable for	Code	Code ESD
10	AL2X upright profiles	MA	MA

The quick-release mechanism is equipped with the standard flat-screen mount 75 x 75 and 100 x 100 for the mounting of all normal flat-screens. The arm is double articulated, turns through a radius of 180° and will extend between 95-425 mm from the upright.



LCD swivel arm MA

LCD swivel arm MA2

Max load kg	Suitable for	Code	Code ESD
15	AL2X upright profiles	MA2	MA2

The quick-release mechanism is equipped with the standard, widely used flat-screen mount 75 x 75 and 100 x 100 for the mounting of all normal flat-screens. The arm is double articulated, turns through a radius of 180° and will extend between 95-425 mm from the upright.



LCD swivel arm MA2

Power channels CJK

Dims mm	Suitable for	Code
Profile 631	AL2X upright profiles	CJK70
Profile 931	AL2X upright profiles	CJK100
3 double sockets (E1) and a switch (E2)		CJK70 SET
Double socket		E1
Switch		E2
Automatic fuse 10 A		E3
Automatic fuse/earth leakage switch 10 A/30 mA		E4
Emergency-stop-switch		E5
Data connector/shielded for Cat.6 cable		E6
Data connector/without screen for Cat.5 cable		E7
Pneumatic, quick coupling 3/8"		E8

Can be fitted with a choice of components, ordered separately. All meet with CE requirements. 3 m cable is included. Supplied wired and ready for use. A finished CJK 70 SET includes 3 double sockets (E1) and a switch (E2). Other sets are also available.



CJK70 SET



Concept workbenches

Concept workbenches are designed for the needs of the electronics industry, where ergonomic qualities are the most important requirement. There are many possible adjustments, all components fit together seamlessly, and each detail is practical in use.

The workstation adapts to the work process and the needs of the operator. As a result all movements of the operator can be optimised, which in turn increases performance and productivity and decreases work-related stress.

Modular design provides total integration with the existing system and the potential to flexibly adapt to changes in the environment. Concept workbenches are typically used in work such as assembly, quality control, and repair.

Concept workbenches are also available in motorised and hand crank versions.



- Ergonomic and highly adaptable to the needs of the user
- Flexible to changes thanks to the modular design
- Suitable for heavy loads
- Offering a wide range of accessories to meet any need

Concept workbench examples



Concept workbench Code C 100 41 037

Qty	Name	Size mm	Code
1	Frame	1500 x 750	100 35 032
1	Laminate bench top	1500 x 750	860 029-69



Concept electric adjustable bench Code C 103 41 037

Qty	Name	Size mm	Code
1	Frame	1500 x 750	103 35 032
1	Laminate bench top	1500 x 750	860 029-69



Concept crank adjustable bench Code C 101 41 037

Qty	Name	Size mm	Code
1	Frame	1500 x 750	101 35 032
1	Laminate bench top	1500 x 750	860 029-69



Concept workstation Code C 100 41 207

Qty	Name	Size mm	Code
1	Frame	1500 x 750	100 35 032
1	Laminate bench top	1500 x 750	860 029-69
1	Upright module	2 x M750	903 35 001
1	Drawer unit 30/15	300 x 454 x 150	859 330-35
1	Fixing set		860 930-35
1	Bar Concept	1500	860 088-35
1	Footrest, bar	550 x 350	860 136-35
1	Light/balancer rail	2 x M750	918 35 006
1	Light HiLite 54	1230	861 954-00
2	Adjustable shelf	720 x 505	920 41 005
2	Perforated back panel		861 511-35
1	LCD-holder		930 35 002
1	Energy rail	440	910 51 001
2	Bin rail	M750	859 151-35
14	Stacking bins		1015-5

The Concept bench can be equipped with castors!



Castor set Ø100 ESD Code 860 429 -00

Castor set Ø100 Code 834 734 -00

Load capacity with castors 300 kg.



Designing Concept workstation

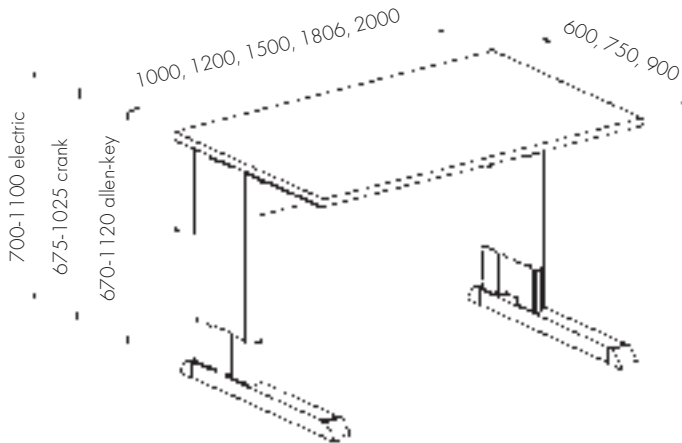

- Select the bench frame and the height adjustment method: allen key, crank or electric.
- Select a bench top to suit the frame: laminate or ESD bench top.



Concept workbench frame

Workbench frame size W x D mm	Bench frame, allen key	Bench frame max load kg	Bench frame, crank adjustable	Bench frame max load kg	Bench frame, electric adjustable	Bench frame max load kg
	Code		Code		Code	
1000 x 600 •	100 35 015	200	101 35 015	200	103 35 015	300
1000 x 750	100 35 030	500	101 35 030	200	103 35 030	300
1200 x 600 •	100 35 016	200	101 35 016	200	103 35 016	300
1200 x 750	100 35 031	500	101 35 031	200	103 35 031	300
1500 x 600 •	100 35 017	200	101 35 017	200	103 35 017	300
1500 x 750	100 35 032	500	101 35 032	200	103 35 032	300
1800 x 600 •	100 35 018	200	101 35 018	200	103 35 018	300
1800 x 750	100 35 033	500	101 35 033	200	103 35 033	300
2000 x 600 •	100 35 019	200			103 35 019	300
2000 x 750	100 35 034	500			103 35 034	300
Bench height steplessly adjustable	670 - 1120 mm		675 - 1025 mm		700 - 1100 mm	



Laminate bench top -69

- Light-grey, speckled laminate surface
- Plastic edging
- Thickness 25 mm



ESD bench top

- Grey laminate surface
- Grey edging
- Thickness 25 mm
- Fixed with screws
- Semi-conductive (ESD)

Concept bench tops

Size W x D mm	Code	Code ESD
1000 x 600 •	860 026-69	TT10060-ESD
1000 x 750	860 590-69	TT10075-ESD
1000 x 900 •	860 593-69	TT10090-ESD
1200 x 600 •	860 027-69	TT12060-ESD
1200 x 750	860 554-69	TT12075-ESD
1200 x 900 •	860 594-69	TT12090-ESD
1500 x 600 •	860 028-69	TT15060-ESD
1500 x 750	860 029-69	TT15075-ESD
1500 x 900	860 031-69	TT15090-ESD
1806 x 600 •	860 580-69	TT18060-ESD
1806 x 750	860 030-69	TT18075-ESD
1806 x 900	860 032-69	TT18090-ESD
2000 x 600 •	860 591-69	TT20060-ESD
2000 x 750	860 592-69	TT20075-ESD
2000 x 900	860 033-69	TT20090-ESD

750 mm deep frames are used with 900 mm deep bench tops.

• = non stock item



900 mm deep bench tops

The extension part 860 634-35 should be used with 900 mm deep bench tops to ensure stability when handling objects heavier than 50 kg on the bench. It is fixed between bench legs and rear case. 2 pieces needed/bench.

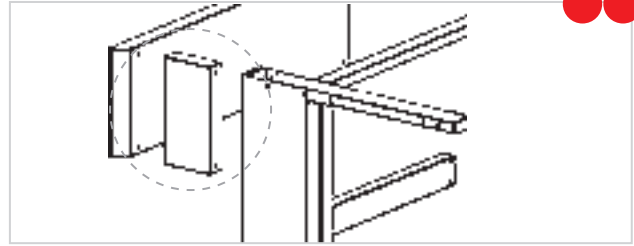

Transport skate

With a transport skate, one person can easily move benches. For long-distance moving, you will need two transport skates.

Name	Max load kg	Code	Code ESD
Transport skate •	180	854 061-41	854 061-35

Compatible with tables with a max depth of 750 mm.



• = non stock item

Colour stripes

You can add colour to the sides of Concept bench legs with plastic stickers. There are four standard colours: blue, green, red and yellow. Colour stripes are not included in the bench frame packs.

Name	Size mm	Colour	Code
Colour stripe pair	530 x 80	green	860 850-00
Colour stripe pair	530 x 80	red	860 851-00
Colour stripe pair	530 x 80	yellow	860 852-00
Colour stripe pair	530 x 80	blue	860 853-00



Concept extension benches



1. Workbench frame,
2. Extension bench frame
3. Corner bench frame

Concept corner bench frame (right)

Name	Size W x D mm	Code
Corner bench frame for a standard bench 600 mm deep •	1000 x 600	111 35 001
Corner bench frame for a standard bench 750 mm deep •	1200 x 600	111 35 002

Concept extension bench frame (right)

Name	Size W x D mm	Code
Extension bench frame •	1500 x 600	112 35 001
Extension bench frame •	1500 x 70	112 35 002
Extension bench frame •	1806 x 750	112 35 003

• = non stock item



The W x D x H rule

All our dimensions follow a WDH rule, where the first dimension is the width (W), the middle the depth (D), and the last the height (H).

Accessories for Concept

These accessories also suit TP benches (NOTE! Not TPH benches).



Upright tubes

Accessories are attached to the Concept bench with the aid of upright tubes or a pre-assembled, upright tube module. The module includes upright tubes, horizontal tube/tubes, corner bracket pair and straight bracket (if module has more than one horizontal tube). The tubes or the module are attached to the back of the bench.

Upright tubes

Name	Size W x D mm	Length (l) mm	Code
Upright tube	30 x 60	500	860 991-35
Upright tube	30 x 60	800	860 142-35
Upright tube	30 x 60	996	860 367-35
Upright tube	30 x 60	1359	860 024-35
Upright tube	30 x 60	1582	860 025-35
Horizontal tube	M500		860 819-35
Horizontal tube	M750		847 402-35
Horizontal tube	M900		840 104-35
Corner bracket pair			848 336-35
Straight bracket			851 827-35



The modular (M) size refers to the distance between two upright tubes from the middle of the tube. The modular size is used to find the appropriate accessories.

Upright tube modules and compatibility

	Suitable for bench widths					Code	Code
	C = Concept					l=1359 mm	l=1582 mm
	1000	1200	1500	1800	2000	h=1075 mm	h=1300 mm
1 x M750	C	C/TP	C	C	C	900 35 001	900 35 002
1 x M900	C	C/TP	C	C	C	901 35 001	901 35 002
2 x M500	C	C				902 35 001	902 35 002
2 x M750			C/TP	C	C	903 35 001	903 35 002
2 x M900				C/TP	C	904 35 001	904 35 002
3 x M500			C	C	C	905 35 001	905 35 002
4 x M500					C	906 35 001	906 35 002

h = module's height measured from Concept bench's top surface.

Aluminium bracket

Name	Code
Aluminium bracket	846 554-00



A separate aluminium bracket (846 554-00) can be used to attach a single tube to any bench.

Light and balancer rail (includes one sliding piece)

Modular size	Width of the front profile mm	Max load kg	Code
2 x M500	1000	15	918 35 001
2 x M500/1500	1500	15	918 35 002
4 x M500	2000	15	918 35 003
M750	750	15	918 35 004
M750/1500	1500	15	918 35 005
2 x M750	1500	15	918 35 006
3 x M750	2250	15	918 35 012
M900	900	15	918 35 007
2 x M900	1800	15	918 35 008
M900/1500	1500	15	918 35 009
M1200	1200	15	918 35 010
M1350	1350	15	918 35 011

Apart from task lights all luminaires are fitted to light/balancer rails which are height and depth adjustable. Tool balancer rails and sliding pieces facilitate the use of heavy equipment. A tool balancer is fixed to the light/balancer rail.

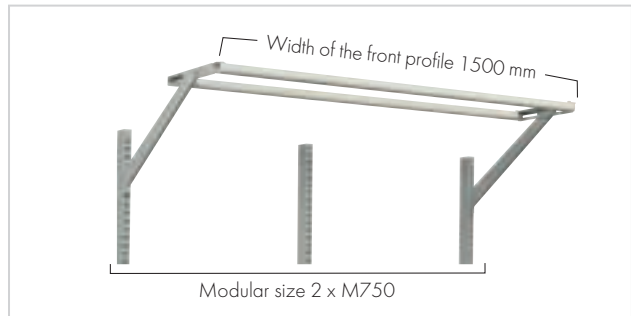
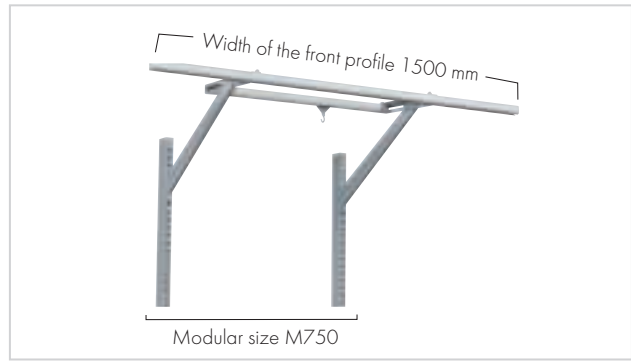

Tool balancers and other supplies

Name	Tool weight kg	Code
Tool balancer 2DU	0,5 - 1	939 502-00
Tool balancer 4DU	1 - 2	939 503-00
Sliding piece		940 453-00



Tool balancer

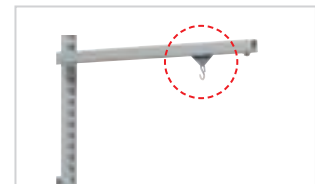

Sliding piece



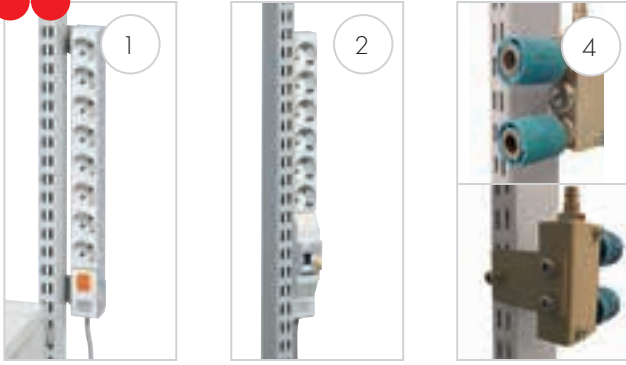

Tailor-made solutions also available



Hide wires and cables with a cable duct.



Fitted to upright tubes, the horizontal cable trough enables cables to be hidden at the top of the workstation.

Energy rails (brackets for uprights included)

Width mm	fixing	Code
1	440 8 sockets + on/off switch	910 51 001
2	440 6 sockets + fault current protection	910 51 002
3	M750 6 sockets + on/off switch	911 51 002
	M900 7 sockets + on/off switch	911 51 003
Bracket pair for perforated panel		853 185-51

Energy rails are available in three module sizes: M500, M750 and M900.

Distributor for compressed air

Connections, Ø 8 mm	In	Out	Fixing	Code	
4	Distributor for compressed air	1	2	horiz./vert.	859 861-00

Connectors are compatible with the CEJN 3200 series.
Can be fitted to all Treston Group benches with upright tubes.

Cable ducts

Name	Size W x H mm	Suitable for module	Code
Cable duct	467 x 360	M500	860 808-35
Cable duct	717 x 360	M750	860 044-35
Cable duct	870 x 360	M900	860 045-35

Fitted to upright tube.

Cable ducts hide the untidy cables from other equipment. This makes it easy to keep the back of the workstation and its surroundings tidy.

Cable troughs

Name	Size W x D x H mm	Suitable for module	Code
Horizontal cable trough	737 x 97 x 45	M750	854 553-35
Horizontal cable trough	890 x 97 x 45	M900	854 554-35
Horizontal cable trough	1187 x 97 x 45	M1200	854 555-35
Horizontal cable trough	1487 x 97 x 45	M1500	854 556-35
Horizontal cable trough	1793 x 97 x 45	M1800	854 557-35
Vertical cable trough	52 x 62 x 1360		861 130-35

Horizontal troughs effectively conceal the cables, without preventing maintenance access.

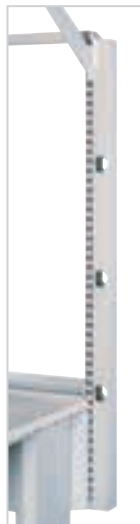

The vertical cable trough is fitted on the side of the upright tube.

Shelves M500

Name	Suitable for module	Size W x D mm	Max load kg	Code
Steel shelf	M500	490 x 300	50	860 804-35
Steel shelf	M500	490 x 400	50	860 805-35
Adjustable shelf •	M500	470 x 505	100	920 35 001
Adjustable shelf •	M500	470 x 650	100	920 35 002
Adjustable shelf, stepless depth adjustment •	M500	470 x 505	50	920 35 003
Adjustable shelf, stepless depth adjustment •	M500	470 x 650	50	920 35 004
Document shelf (tilting 10-75°)	M500	470 x 265	5	860 806-35

Shelves M750

Name	Suitable for module	Size W x D mm	Max load kg	Code
Steel shelf	M750	740 x 300	50	836 028-35
Steel shelf	M750	740 x 400	50	852 770-35
Adjustable shelf	M750	720 x 505	100	920 35 005
Adjustable shelf	M750	720 x 650	100	920 35 006
Adjustable shelf, stepless depth adjustment	M750	720 x 505	50	920 35 007
Adjustable shelf, stepless depth adjustment	M750	720 x 650	50	920 35 008
Extendable shelf •	M750	720 x 390	30	925 35 002
Document shelf (tilting 10-75°)	M750	720 x 265	5	860 115-35

Shelves M900

Name	Suitable for module	Size W x D mm	Max load kg	Code
Steel shelf	M900	890 x 300	50	852 283-35
Steel shelf	M900	890 x 400	50	852 769-35
Adjustable shelf	M900	870 x 505	100	920 35 009
Adjustable shelf	M900	870 x 650	100	920 35 010
Adjustable shelf, stepless depth adjustment	M900	870 x 505	50	920 35 011
Adjustable shelf, stepless depth adjustment	M900	870 x 650	50	920 35 012
Extendable shelf •	M900	870 x 390	30	925 35 003
Document shelf (tilting 10-75°)	M900	870 x 265	5	860 399-35

Shelves M1200

Name	Suitable for module	Size W x D mm	Max load kg	Code
Steel shelf •	M1200	1167 x 300	80	854 480-35
Steel shelf •	M1200	1167 x 400	80	854 483-35

Shelves M1350

Name	Suitable for module	Size W x D mm	Max load kg	Code
Steel shelf •	M1350	1340 x 300	50	860 787-35
Steel shelf •	M1350	1340 x 400	50	860 788-35
Adjustable shelf •	M1350	1320 x 505	100	920 35 013
Adjustable shelf •	M1350	1320 x 650	100	920 35 014

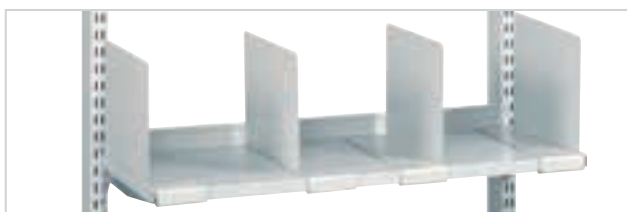

• = non stock item



Steel shelf



Adjustable shelf



Steplessly adjustable shelf

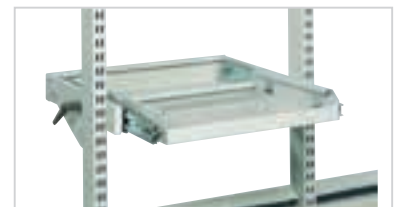

Extendable shelf

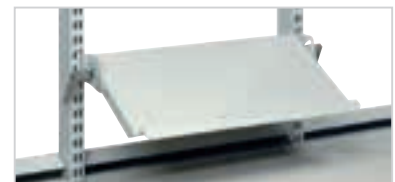

Document shelf

Shelves M1500

Name	Suitable for module	Size W x D mm	Max load kg	Code
Steel shelf •	M1500	1467 x 300	80	854 481-35
Steel shelf •	M1500	1467 x 400	80	854 484-35

Shelves M1800 + corner shelf

Name	Suitable for module	Size W x D mm	Max load kg	Code
Steel shelf •	M1800	1773 x 300	80	854 482-35
Steel shelf •	M1800	1773 x 400	80	854 485-35
Corner shelf •		1318 x 400	80	854 479-35

Divider pair for shelves M500, M750 and M900

Name	Size W x D mm	Code
Divider pair	285 x 190	010 004-35
Divider pair	385 x 190	010 005-35

Divider pair for shelves M1200, M1500 and M1800

Name	Size W x D mm	Code
Divider pair	285 x 190	861 116-35



Adjustable auxiliary shelf

Adjustable auxiliary shelf

Name	Size W x D mm	Tilting	Max load kg	Code	Code ESD
Adjustable auxiliary top	560 x 340	0-25°	15	927 41 001	927 35 001
Adjustable auxiliary top	605 x 405	0-25°	15	927 41 002	927 35 002

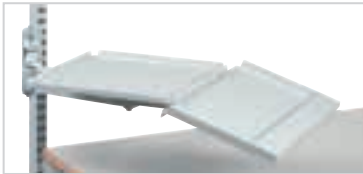

Monitor shelf & keyboard tray

IT shelves and trays

Name	Size W x D mm	Max load kg	Code
Monitor shelf with arm	365 x 365	25	930 35 001
Keyboard tray for monitor shelf •	480 x 270	5	860 904-35
Keyboard and mouse tray for monitor shelf	620 x 270	5	860 903-35
LCD holder with double arm		15	930 35 002
Keyboard tray for LCD holder	480 x 260	5	860 941-35
Keyboard and mouse tray for LCD holder	620 x 260	5	860 942-35
Keyboard tray (attached to the bench top)	630 x 400	10	925 35 001

• = non stock item



LCD-holder & keyboard tray

Document holders

Name	Size W x D mm	Max load kg	Code
Document holder A4	290 x 330	5	928 35 008
Document holder A3	418 x 330	5	928 35 009

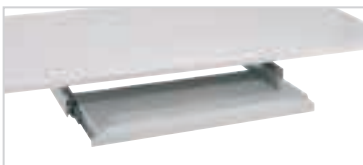

Keyboard tray

Replacement arms (spare parts)

Name	Length mm	Max load kg	Code
Double arm, 40 mm	200+200	10	880 020-35
Double arm, 60 mm	200+200	15	880 010-35
Heavy arm, 60 mm	287+221	30	860 993-35
Height-adjustable arm with gas spring, 60 mm	375	15	860 985-35
Height-adjustable profile		15	860 997-35



Document holder



Double arm

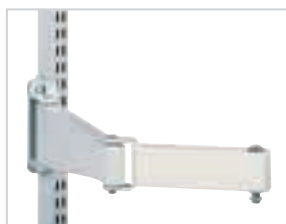

Heavy arm

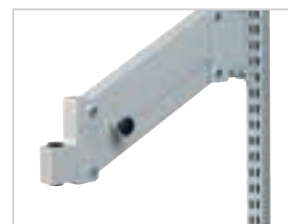

Height-adjustable arm



Height-adjustable profile



When a position changes, the height must be adjusted

Frequent changes in the working position, such as changing from a sitting position to a standing position, require height-adjustable arm (860 985-35). The height-adjustable profile (860 997-35) can be attached to any rack with arm (such as the PC rack) that is pulled down and lifted back up according to the working position. The adjustment range is 450 mm.



Auxiliary top, fixed brackets

Name	Size W x D mm	Max load kg	Code	Code ESD
Auxiliary top left	400 x 500	40	926 41 001	926 35 001 •
Auxiliary top right	400 x 500	40	926 41 002	926 35 002 •

• = non stock item



Trays

Name	Size W x D mm	Max load kg	Code
Equipment tray	250 x 250 x 90	10	928 35 001
Equipment tray	500 x 250 x 125	15	928 35 002
Equipment tray *	500 x 250 x 125	30	928 35 003
Bin shelf	560 x 175 x 125	15	928 35 005
Bin shelf •	600 x 220 x 125	15	928 35 006
Stand for picking bins** •	560 x 165 x 355		931 35 000

* Comes with heavy arm.

** Space for 15 picking bins 30-1L-4ESD

• = non stock item

Bin rails with arms

Name	Size W x D mm	Max load kg	Code
Curved bin rail with arm	770 x 54	15	929 35 002
Extension for curved bin rail with arm	770 x 54		860 911-35

Tool panel

Name	Size W x D mm	Max load kg	Code
Tool panel	267 x 305	5	928 35 010

Rotating tool panels

Name	Size W x D mm	Max load kg	Code
Rotating tool panel, height-adjustable arm	513 x 320	15	860 864-35
Rotating tool panel, double arm	513 x 320	15	880 865-35
Perforated panel	470 x 300		860 951-35
Tool trough M500	470 x 150		860 952-35
Bin rail M500	492 x 90	50	860 811-35
Light bin rail M500	492 x 54	10	860 953-35



Equipment tray



Bin shelf



Stand for stacking bins



Curved bin rail with extension rail

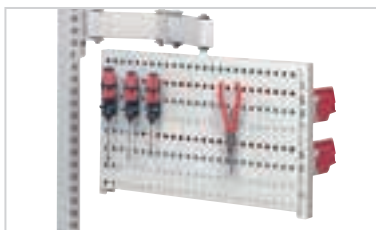

Rotating tool panel with perforated panel and R-hooks

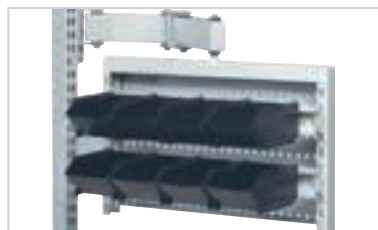

Rotating tool panel with M500 perforated panel, M500 bin rails and 8 plastic ESD bins



Tool panel

Plastic bins, hooks and tools in pictures are not included.



Rotating tool panel

The rotating tool panel can be equipped with perforated panels and tool troughs. The rotating tool panel is compatible with all M500 accessories, such as the tool trough and the bin rails.

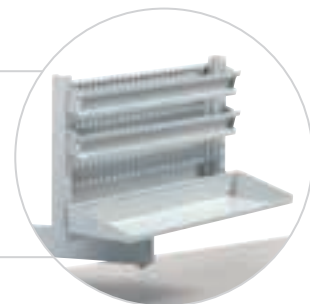

Other supplies

Name	Code
Bottle holder (Ø 100) for upright tube	859 063-35
Roll holder for upright tube (roll ø height 150 mm, width 175 mm)	860 841-35



Bottle holder



Roll holder

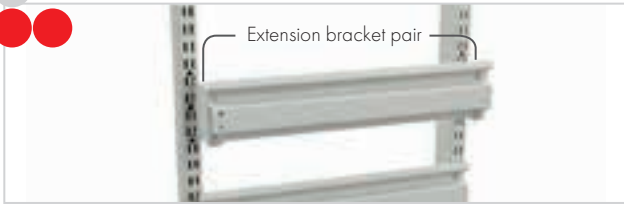

Bin rail M750 with brackets and blue stacking bins.



Light bin rail M750 with brackets and red stacking bins.

Bin rails

Name	Suitable for module	Size W x D mm	Max load kg	Code
Bin rail	M500	492 x 100	50	859 150-35
Light bin rail *	M500	492 x 54	10	860 953-35
Bin rail	M750	742 x 100	50	859 151-35
Light bin rail *	M750	742 x 54	10	860 955-35
Bin rail	M900	895 x 100	50	859 152-35
Light bin rail *	M900	895 x 54	10	860 956-35
Bin rail	M1350	1343 x 100	50	859 153-35
Bin rail	M1500	1493 x 100	50	859 154-35
Bin rail	M1800	1799 x 100	50	859 155-35
Extension bracket pair		60	50	860 919-35

* Suitable only for picking bins 30-1L, 30-2L and 30-23L.

Another way of ensuring an ergonomic working position and saving space is to use bin rails. The higher the stacks are, the further they are from the workstation. To ensure an ergonomic working position, use extension bracket pair on the top. The bin rails are available in six standard module sizes.

Stacking bins

No.	Capacity l	Outer dims W x D x H mm	Inner dims W x D x H mm	Pack pcs	Code.* blue	Code.* red	Code.* ESD black	Labels + shields	Pack min. order	Cross divider
1	1,0	105 x 165 x 75	90 x 105 x 65	60	1015-6	1015-5	1015-4 ESD	E10	60	
	3,6	149 x 250 x 130	125 x 185 x 115	30	1525-6	1525-5	1525-4 ESD	E15	30	V-14
	6,5	186 x 300 x 156	155 x 230 x 140	24	1930-6	1930-5	1930-4 ESD	E20	24	V-19
	8,7	186 x 400 x 156	155 x 330 x 140	24	1940-6	1940-5	1940-4 ESD	E20	24	V-19
2	1,0	99 x 160 x 70	85 x 100 x 62	60	30-1L-6		30-1L-4 ESD			
	1,7	198 x 160 x 70	175 x 100 x 62	30	30-2L-6		30-2L-4 ESD			
	1,7	198 x 160 x 70	175 x 100 x 62	30	30-23L-6		30-23L-4 ESD			
										(2 fixed length dividers)

*] Order number/one item. All bins are also available in grey colour.

Labels and cross dividers

Fixing stacking bins on the bin rail

Bin rail	M500	M750	M900	M1350	M1500	M1800	Curved bin rail
1015	4	7	8	12	14	17	
1525	3	5	6	9	10	12	
1930 & 1940	2	4	4	7	8	9	
30-1L	5	7	9	13	15	17	5
30-2L & 30-23L	2	3	4	7	7	9	



Shelf bins

Capacity l	Outer dims W x D x H mm	Inner dims W x D x H mm	Pack pcs	Code.* blue	Code.* red	Code.* ESD black	Code.*	Number /bin
1,9	92 x 400 x 82	75 x 357 x 70	30	4010-6	4010-5	4010-4 ESD	D-10	6
2,4	92 x 500 x 82	75 x 457 x 70	30	5010-6	5010-5	5010-4 ESD	D-10	8
4,2	186 x 400 x 82	167 x 357 x 70	15	4020-6	4020-5	4020-4 ESD	D-20	6
5,3	186 x 500 x 82	167 x 457 x 70	15	5020-6	5020-5	5020-4 ESD	D-20	8
6,5	186 x 600 x 82	167 x 557 x 70	15	6020-6	6020-5	6020-4 ESD	D-20	10

*] Order number/one items. All bins are also available in grey colour.

Cross dividers

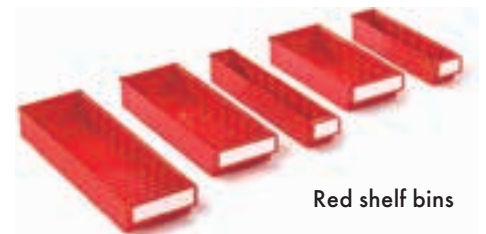

Red shelf bins



Small storage cabinets

Name	Module size	Size W x D x H mm	Max load kg	Code
Perforated tool cabinet	M500	470 x 250 x 600	20	854 039-07
Perforated tool cabinet	M750	720 x 255 x 900	60	852 629-07
Sliding door cabinet	M750	720 x 370 x 400	40	860 970-35
Shelf for M750 perforated tool cabinet		715 x 175 x 15	10	836 273-35
File cabinet with two shelves	M750	720 x 330 x 900	60	860 980-35
CD/folder box, fitted to upright tube	M750	130 x 290 x 330	5	860 983-35



Perforated tool cabinet



Sliding door cabinet



File cabinet with two shelves

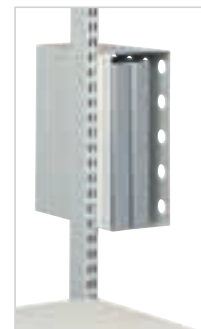

CD/folder box

CPU cabinets and holders

Name	Size W x D x H mm	Max load kg	Suitable for	Code
1. CPU holder, bar clamp	>150 x 500 x 85	20	Concept benches	860 551-35
CPU holder	180-225 x 450 x 50	20	Concept benches	860 552-35
CPU holder	180-225 x 450 x 50	20	Concept benches, electric adj.	860 740-35
2. CPU holder	180-225 x 450 x 50	20	TP upright frame	860 553-35
3. CPU holder	180-225 x 450 x 50	20	TP benches	854 440-35
4. CPU cabinet *	325 x 550 x 560	40	all benches, except TP upright frame	861 120-35
5. Tool cabinet *	325 x 525 x 560	40	all benches, except TP upright frame	861 121-35

*Fixed under bench top, fastening set for Concept bench see page 82 (same as fastening set for drawer unit 45). In WB/TP benches brackets are included.



1. CPU holder, bar clamp

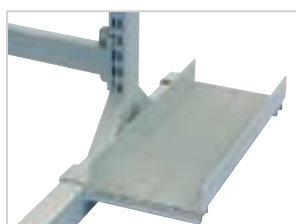

2. CPU holder



3. CPU holder



4. CPU cabinet



5. Tool cabinet

Bars

Name	Bench frame width mm	Depth adjustment mm	Code
Bar Concept •	1000	-	860 084-35
Bar Concept	1200	-	860 085-35
Bar Concept	1500	150	860 088-35
Bar Concept	1800	150	860 089-35
Bar Concept	2000	150	860 090-35

The bar can be used to fix a footrest, a small cabinet or a CPU holder. The bar is included with the crank and electric adjustable Concept benches.

• = non stock item

Footrests

Name	Size W x D mm	Height	Tilting	Suitable for	Code ESD
Footrest, bar	550 x 350	90-280	5-30	Concept	860 136-35
Footrest, bar, with gas action	550 x 350	90-260	5-30	Concept	860 196-35

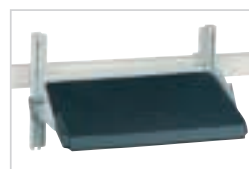

Footrest, bar



Footrest, bar, with gas action



MultiLine assembly solutions

Material flow to effective workstations

In the assembly industry, workstations are well planned and designed since they must function as well as possible. MultiLine is expressly designed as an accessory for Treston Group workspace solutions. Its underlying concept is simple: by connecting workstations to a transfer line you can achieve a more flexible and controllable material flow between workstations without sacrificing characteristics such as usability or ergonomics.

Low investment costs

The MultiLine transfer system has two characteristics, due to which its investment costs remain low. Firstly, it is integrated with an existing system, complementing current processes and thereby avoiding the need for additional investments. Secondly, it is built using standard parts and design, which makes it easy to adapt to any situation and space. It can also be easily and quickly modified when the layout changes.

Optimised for WIP

The core of WIP logic (work in process) comprises allocating a value to stored items between production phases. Money is wasted when half-ready products or components lie unused e.g. in a trolley used as a buffer. If MultiLine is used, only a small quantity of half-finished products lies waiting between production phases.

This problem is amplified if a mistake made in one phase remains unnoticed until a trolley full of defective components is brought to the next phase. With MultiLine both the cost per mistake and the number of mistakes are significantly minimised, because only a few faulty products can be produced before the mistake is noticed.



More information on MultiLine assembly solutions on a separate brochure.

Trolley used as a buffer



Manual transfer line





FlexFlow flow-through shelving

FlexFlow flow-through shelving can be used as a standalone solution or integrated into a single workstation or assembly line, resulting in faster throughput, less work in process, higher productivity and managed inventories. Your assembly process as a whole will become simpler and more efficient.

FlexFlow is a flexible solution that allows easy addition and removal of components as the role of the workstation changes. FlexFlow can easily be customised to your application and operator using a wide range of accessories. When FlexFlow is equipped for, and adjusted to individual needs the whole production process benefits.

FlexFlow module sizes

FlexFlow is based on module sizes in order to allow it to be easily integrated with other Treston Group workspace solutions and the MultiLine transfer system. The available sizes are M750 and M900. Both the width and the depth can be increased by combining standard modules that are M750, M900 and M1350 in width, and 900 mm in depth.

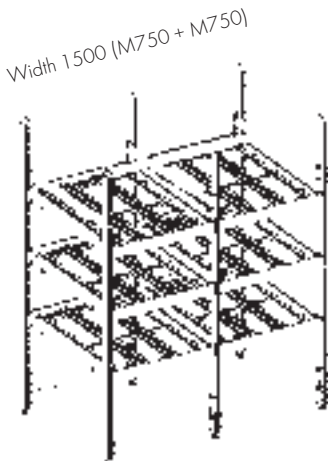

! More information on FlexFlow flow-through shelving on a separate brochure.





TP and TPH workbenches

The classically designed TP workbench is the ideal basic bench, the simplest and the most cost-effective option in our range of workbenches. TP workbenches are standard benches that are suitable for a broad range of tasks and environments when fitted with accessories: testing, packing, repairing, inspecting. TP bench is guaranteed for regular use with loads up to 300 kg.

Designed for use in today's production and assembly environments, this definitive modular system, developed over more than 35 years, provides a high quality working environment. Customise your workstation to your own requirements.

Stepless height adjustment

The height of workbenches in our TP range can be steplessly adjusted from 650 to 900 mm, which makes these benches suitable for work while sitting or standing. Packing is a typical example of work where the workbench height must be set correctly for the height of the user.



- Steel structure
- A cost-effective option to start with
- Easy to equip with a variety of accessories
- Concept accessories available



TP and TPH workbench examples



TP workbench Code C 120 41 300

Qty	Name	Size mm	Code
1	Workbench TP	1500 x 700	TP715
1	Accessory frame	1500	TPK15-35
1	Upright tube module	2 x M750	903 350 01



TP upright frame with bench top Code C 123 35 102

Qty	Name	Size mm	Code
1	TP upright frame	M900 x 1850	123 35 008
1	ESD bench top	1200 x 600	TT12060-ESD
1	Bracket pair		860 139-35



TP workbench Code C 120 41 302

Qty	Name	Size mm	Code
1	Workbench TP	1500 x 700	TP715
1	Accessory frame	1500	TPK15-35
1	Upright tube module	2 x M750	903 350 01
1	Light/balancer rail	2 x M750	918 350 06
1	ProLite 28 light	1230	861 928 00
2	Metal shelf	M750 x 300	836 028-35
2	Bin profile	M750	859 151-35
10	Stacking bin		1525-5



TPH workbench

Qty	Name	Size mm	Code
1	Workbench TPH	1500 x 700	TPH715
1	Drawer unit 45/14, 1x100 drawer		603 35 002



The TP bench can be equipped with castors!

Castor set Ø100 Order No 834 734 -00

Castor set Ø100 ESD Order No 860 429 -00

Load capacity with castors 300 kg.

TP workbench

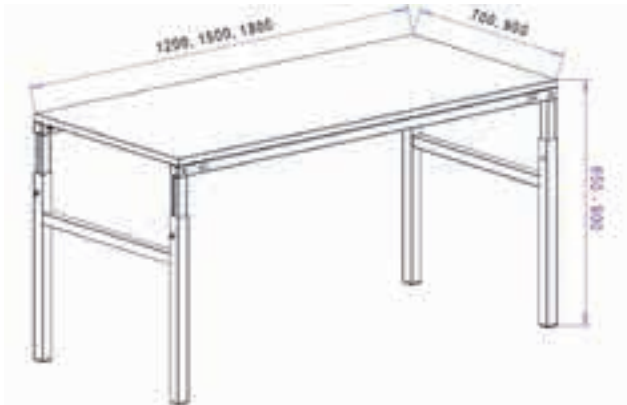

- Stepless height adjustment with allen-key between 650-900 mm.
- Frames are of epoxy powder coated steel in grey RAL 7035.
- Upright tubes (ordered separately) allow to attach a wide range of accessories.

TP workbench

Bench size W x D mm	Max load kg	Code	Code ESD
700 x 500	150	TP507	TP507 ESD
1000 x 500	150	TP510	TP510 ESD
1500 x 500	150	TP515	TP515 ESD
1000 x 700	300	TP710	TP710 ESD
1200 x 700	300	TP712	TP712 ESD
1500 x 700	300	TP715	TP715 ESD
1800 x 700	300	TP718	TP718 ESD
1500 x 900	300	TP915	TP915 ESD
1800 x 900	300	TP918	TP918 ESD



Laminate bench top

- 25 mm low pressure laminate
- Light grey surface
- Plastic edging



ESD bench top

- Grey laminate surface
- Grey edging
- Thickness 25 mm
- Semi-conductive (ESD)



Lower shelf for TP

Not enough space above the workstation? Then utilise the space below. The lower shelf for TP bench simply hangs on the horizontal bars.

Name	Size W x D mm	Max load kg	Code
Lower shelf	1080 x 500	50	AT120 TPH
Lower shelf	1380 x 500	50	AT150 TPH
Lower shelf	1680 x 500	50	AT180 TPH



Trolley with a lower shelf and handle.

SAP trolley

Construction as TP bench. Height adjustment with allen key between 650-900 mm. Swivel castors (Ø 100 mm), two of which have brakes. Load capacity 150 kg. Lower shelf and push handle available separately.

Name	Size W x D mm	Max load kg	Code	Code ESD
Trolley	700 x 500	150	SAP507	SAP507 ESD
Trolley	1000 x 700	150	SAP710	SAP710 ESD
Trolley	1500 x 700	150	SAP715	SAP715 ESD
Lower shelf	700 x 500	40	AT507	AT507 ESD
Lower shelf	1000 x 700	40	AT710	AT710 ESD
Handle	depth 500		PUSH50	PUSH50
Handle	depth 700		PUSH70	PUSH70



TP extension benches

TP line extension

Each standard TP bench may also be supplied as a line extension. Fitted to side of main bench.

Bench size W x D mm	Max load kg	Code	Code ESD
1000 x 700	150	TP710 L	TP710 L ESD
1200 x 700	150	TP712 L	TP712 L ESD
1500 x 700	150	TP715 L	TP715 L ESD
1800 x 700	150	TP718 L	TP718 L ESD
1500 x 900	150	TP915 L	TP915 L ESD
1800 x 900	150	TP918 L	TP918 L ESD

TP angle extension

Each standard TP bench may also be supplied as an angle extension. Fitted to front angle of main bench.

Bench size W x D mm	Max load kg	Code	Code ESD
1000 x 500	150	TP510 K	TP510 K ESD
1200 x 700	150	TP712 K	TP712 K ESD

TP corner workbench

A corner workbench can be used with two TP benches (with one H-frame pair) to create a 90° angle setup.

Bench size W x D mm	Max load kg	Code	Code ESD
1100 x 1100	150	TP707 KK	TP707 KK ESD
1300 x 1300	150	TP909 KK	TP909 KK ESD



This unit consists of a worktop, two side frames and a leg in the middle. Front side 565 mm.

TP upright tubes

The TP workbench is a cost-effective option to the modular Concept workbench. Accessories are attached to both benches with the aid of upright tubes or a pre-assembled, upright tube module.

The module includes upright tubes, horizontal tube/tubes, corner bracket pair and straight bracket (if module has more than one horizontal tube). The upright tubes or the upright tube module are attached to the back of the TP bench with accessory frame (ordered separately).

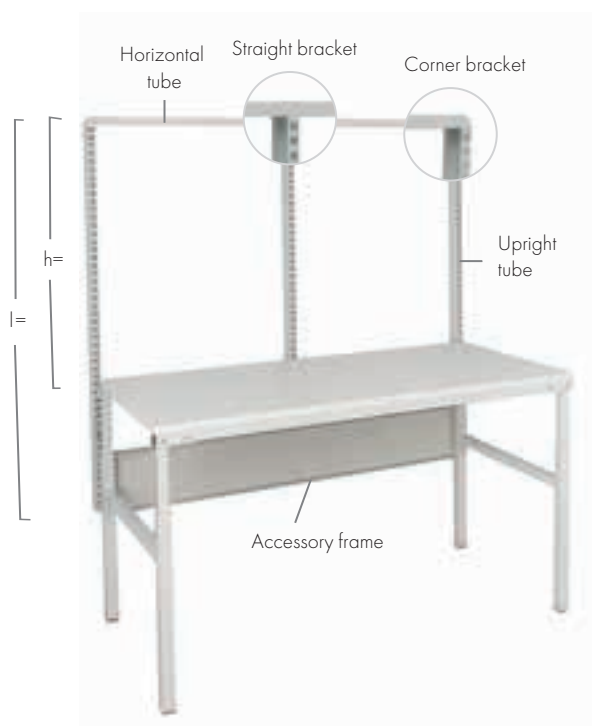

Accessories from page 30

TP bench with upright tubes can be equipped with Concept accessories.



Accessory frame

Upright tubes

Name	Size W x D mm	Length (l) mm	Code
Upright tube	30 x 60	500	860 991-35
Upright tube	30 x 60	800	860 142-35
Upright tube	30 x 60	996	860 367-35
Upright tube	30 x 60	1359	860 024-35
Upright tube	30 x 60	1582	860 025-35
Horizontal tube	M500		860 819-35
Horizontal tube	M750		847 402-35
Horizontal tube	M900		840 104-35
Corner bracket pair			848 336-35
Straight bracket			851 827-35



Upright tube with aluminium bracket attached to the bench.



Bench top & brackets for TP upright frame

Size W x H mm	Max load kg	Code laminated bench top	Code ESD bench top
1200 x 600	60	860 027-69	TT12060-ESD
Corner bracket pair		860 139-35	

Accessory frame

Bench frame width mm	Fixing points for uprights	Code
1200	1 x M750, 1 x M900, 1 x M1200	TPK12-35
1500	1 x M1500, 2 x M750	TPK15-35
1800	1 x M1800, 2 x M900	TPK18-35

Upright tubes or the upright tube module are always attached to TP bench with accessory frame. The accessory frame cannot be used on line or corner extensions.

Upright tube modules and compatibility

	Suitable for bench widths C = Concept					Code l=1359 mm	Code l=1582 mm
	1000	1200	1500	1800	2000	h=1075 mm	h=1300 mm
1 x M750	C	C/TP	C	C	C	900 35 001	900 35 002
1 x M900	C	C/TP	C	C	C	901 35 001	901 35 002
2 x M500	C	C				902 35 001	902 35 002
2 x M750			C/TP	C	C	903 35 001	903 35 002
2 x M900				C/TP	C	904 35 001	904 35 002
3 x M500			C	C	C	905 35 001	905 35 002
4 x M500					C	906 35 001	906 35 002

h = module's height measured from the bench top surface

Aluminium bracket

Name	Code
Aluminium bracket	846 554-00

Bracket can be used to attached a single tube to the bench.

TP upright frame with bench top

TP upright frame with bench top is a lighter version of the TP workbench. In addition to the bench top attached to the frame, it can be equipped with any of the Concept accessories. It's ideal for lighter use, when some additional workspace is needed.

TP upright frame

Size W x D mm	Max load kg	Code
M750 x 1500 •	300	123 35 005
M750 x 1850 •	300	123 35 006
M900 x 1500 •	300	123 35 007
M900 x 1850 •	300	123 35 008



Laminated bench top -69

- Light-grey, speckled laminate surface
- Plastic edging
- Thickness 25 mm



TPH workbench

The TPH workbench already includes a pair of uprights and one shelf; composing our best selling workstation set. It has its own range of accessories, also in stock, and covering the essential, basic needs of any professional workstation.

Height adjustment with allen-key between 650-900 mm. Workbench with upright profiles and a laminate shelf, height adjustment between 1080-1550 mm, load capacity 50 kg. Construction as TP.



Workbench TPH

Bench size W x D mm	Shelf size W x D mm	Max load kg	Code	Code ESD
1200 x 700	1200 x 310	300	TPH712	TPH712 ESD
1500 x 700	1500 x 310	300	TPH715	TPH715 ESD
1800 x 700	1800 x 310	300	TPH718	TPH718 ESD
1500 x 900	1500 x 310	300	TPH915	TPH915 ESD
1800 x 900	1800 x 310	300	TPH918	TPH918 ESD



Accessories on page 46

There is a large range of workbench accessories available.



TPH715*

TPH707 KK

TPH715*

* Workbench with one H-frame pair.

TPH corner workbench

A corner workbench can be used with two TPH workstations (with one H-frame pair) to create a 90° angle setup. This unit consists of a worktop and all necessary components. Load capacity 150 kg. Front side 565 mm.

Bench size W x D mm	Max load kg	Code	Code ESD
1100 x 1100	150	TPH707 KK	TPH707 KK ESD
1300 x 1300	150	TPH909 KK	TPH909 KK ESD

Power channels for TPH

Dims mm	Suitable for	Code
Profile 1058	TPH712	TJK120
Profile 1358	TPH715/915	TJK150
Profile 1658	TPH718/918	TJK180
Includes 3 x E1, E2	TPH715/915	TJK150 SET
Includes 3 x E1, E2	TPH718/918	TJK180 SET
Double socket		E1
Switch		E2
Automatic fuse 10 A		E3
Automatic fuse/earth leakage switch 10 A/30 mA		E4
Emergency-stop-switch		E5
Data connector/shielded for Cat.6 cable		E6
Data connector/without screen for Cat.5 cable		E7
Pneumatic, quick coupling 3/8"		E8

The finished TJK 150 SET and TJK 180 SET include 3 double sockets (E1) and a switch (E2). (Other SETs are also available.)

Power channels for TPH

Constructed from aluminium profile, this range of compact power channels provides power distribution for TPH benches. Pre-assembled with a choice of components, ordered separately. The power channel is isolated from the workbench. 3 m cable is included. Aluminium profile 72 x 72 mm. All meet with CE requirements.



Power channel TJK

Accessories for TPH

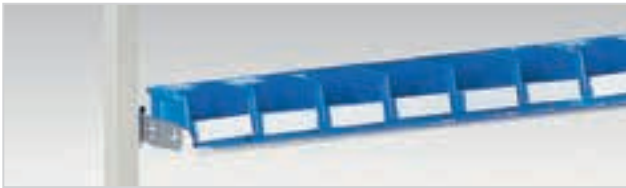

Metal shelf TH



Bin profile BP



Auxiliary shelf SH



Perforated panel RL



Tool and lighting support KT



Swivel arm with tray CKV

Metal shelf TH

Size W x D mm	Max load kg	Suitable for	Code	Code ESD
1119 x 145	30	TPH712	TH120	TH120 ESD
1419 x 145	30	TPH715/915	TH150	TH150 ESD
1719 x 145	30	TPH718/918	TH180	TH180 ESD

Adjustment for depth, height and angle. For stacking and picking bins. Load capacity 30 kg.

Bin profile BP

Width mm	Max load kg	Suitable for	Code	Code ESD
profile 1115	15	TPH712	BP120	BP120 ESD
profile 1415	15	TPH715/915	BP150	BP150 ESD
profile 1715	15	TPH718/918	BP180	BP180 ESD

Aluminium profile for stacking and picking bins.

Auxiliary shelf SH

Size W x D mm	Max load kg	Suitable for	Code	Code ESD
1200 x 310	50	TPH712	SH120	SH120 ESD
1500 x 310	50	TPH715/915	SH150	SH150 ESD
1800 x 310	50	TPH718/918	SH180	SH180 ESD

Height adjustable shelf. 25 mm laminated particle board.

Perforated panel RL

Size W x H mm	Suitable for	Code	Code ESD
1115 x 750	TPH712	RL120	RL120
1415 x 750	TPH715/915	RL150	RL150
1715 x 750	TPH718/918	RL180	RL180
Panel hooks for TPH	TPH	RK1	RK1

Robust, perforated steel panel. 9 mm perforations at 38 mm centres. Mount on TPH-benches with connectors RK 1. Can also be attached to a wall with screws (included).

Tool and lighting support KT

	Size W x D mm	Suitable for	Code	Code ESD
	1200 x 600	TPH712	KT120	KT120
	1500 x 600	TPH715/915	KT150	KT150
	1800 x 600	TPH718/918	KT180	KT180
Extra C-profile	1500	KT150	SPR150	SPR150
Extra C-profile	1800	KT180	SPR180	SPR180

For suspending power tools and lighting units. Includes one C-profile bar with sliding hook.

Swivel arm with tray CKV

Size W x D mm	Max load kg	Suitable for	Code	Code ESD
Tray 210 x 460	15	TPH	CKV400	CKV400 ESD

Swivel arm with lockable, angle adjustable steel tray. Load 15 kg. Mount on C-profile.

Upright profiles HKCP

Height mm	Suitable for	Code	Code ESD
1470	TPH	HKCP147	HKCP147

If you mount both perforated panel RL and cable channel TJK to TPH benches, you must order extra-high upright profiles.

Component rack EPL

Size W x D x H mm	Suitable for	Shelves number	Code ESD
455 x 200 x 290	CKV	3	EPL12 ESD

Rack with three fixed shelves. Of semiconductive epoxy powder coated steel in light grey (RAL 7035).

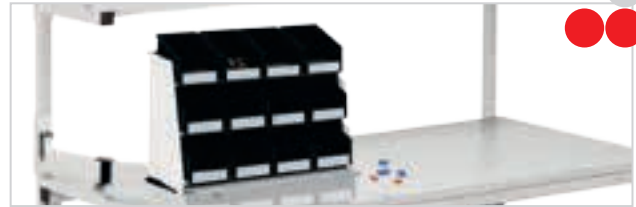

Component rack EPL

Cable tidy TPHCT

Size W x D x H mm	Suitable for	Code	Code ESD
1115 x 45 x 205	TPH712	TPHCT120	TPHCT120
1415 x 45 x 205	TPH715/915	TPHCT150	TPHCT150
1715 x 45 x 205	TPH718/918	TPHCT180	TPHCT180

Mounted between C-profiles below worktop. Of perforated epoxy powder coated steel.



Cable tidy TPHCT

Cable clip set CC

Set	Max load kg	Suitable for	Code	Code ESD
5 pcs/set	15	TPH	CC12	CC 12

The cable clip set will hold cables etc. securely and neatly in place along the bench frame. The clips locate in the 12 mm profile slot.



Cable clip set CC

PC stand CPU

Width mm	Height mm	Suitable for	Code	Code ESD
130-240	395-500	WB and TP/TPH benches, CPU SAP/CTR/WTR trolleys	CPU	CPU
340-460	180-285			

An adjustable holder for either vertical or horizontal CPU, to mount underneath the bench worktop.



PC stand CPU

LCD bracket MH

Max load kg	Suitable for	Code	Code ESD
15	WB/TPH benches and WTR trolley	MH	MH

The quick-release mechanism is equipped with the standard used flat-screen mount 75 x 75 and 100 x 100 for the mounting of all normal flat-screens. Connector HKC-MH/MA needed for mounting to TPH benches, ordered separately.



LCD bracket MH

LCD swivel arm MA

Max load kg	Suitable for	Code	Code ESD
10	WB/TPH benches and WTR trolley	MA	MA

The quick-release mechanism is equipped with the standard flat-screen mount 75 x 75 and 100 x 100 for the mounting of all normal flat-screens. The arm is double articulated, turns through a radius of 180° and will extend between 95-425 mm from the upright. Connector HKC-MH/MA needed for mounting LCD swivel arm MA to TPH benches, ordered separately.



LCD swivel arm MA

LCD swivel arm MA2

Max load kg	Suitable for	Code	Code ESD
15	WB/TPH benches and WTR trolley	MA2	MA2

The quick-release mechanism is equipped with the standard, widely used flat-screen mount 75 x 75 and 100 x 100 for the mounting of all normal flat-screens. The arm is double articulated, turns through a radius of 180° and will extend between 95-425 mm from the upright. Connector HKC-MH/MA needed for mounting LCD swivel arm MA2 to TPH benches, ordered separately.



LCD swivel arm MA2

Connector HKC

Suitable for	Code
LCD bracket MH	HKC-MH
LCD swivel arm MA/MA2	HKC-MA

Connector HKC-MH/MA is needed for mounting LCD bracket /swivel arm MA to TPH benches.



Accessories that suit all benches

Accessories attached to the bench top

Name	Size W x D x H mm	Max load kg	Suitable for	Code
Equipment tray with bench top fixing •	250 x 250 x 90	5	all benches	860 885-35
Document holder A4 with bench top fixing •	290 x 330	5	all benches	860 882-35
Tool panel with bench top fixing •	267 x 305	5	all benches	860 883-35
Bin rail with bench top fixing •	315 x 72	5	all benches	860 884-35
Light arm, bench top fixing •	200	5	all benches	860 990-35
Bag holder for bench top lower edge			all benches	860 840-35
Keyboard tray NT	500 x 250 x 110		WB and TP/TPH benches, SAP/WTR trolleys	NT 500 ESD
Bench top turntable, ESD	Ø 475		all benches	847 145-00
CPU cabinet*	325 x 550 x 560	40	all benches, except TP upright frame	861 120-35
Tool cabinet*	325 x 525 x 560	40	all benches, except TP upright frame	861 121-35

*Fixed under bench top, fastening set for Concept bench see page 82 (same as fastening set for drawer unit 45). In WB/TP benches brackets are included.



Equipment tray



Document holder



Tool panel



Bin rail



Light arm



Bag holder



Keyboard tray NT



Bench top turntable



CPU cabinet



Tool cabinet

Outlet panel PRK 5

Dims mm	Suitable for	Code
5 Schuco wall sockets, switch and 3 m cable	WB and TP/TPH benches, CTR/SAP/WTR trolleys.	PRK5

Mount on upright profiles with connectors (included). Can also be attached under the laminate shelf with screws.





Footrests

Name	Size W x D mm	Height	Tilting	Suitable for	Code	Code ESD
Footrest, floor •	550 x 350	100	5-30	All benches		860 947-35
Footrest, floor, height adjustable	550 x 350	90-280	5-30	All benches		860 137-35
Footrest, floor, with gas action	550 x 350	90-260	5-30	All benches		860 224-35
Footrest JT2*	500 x 370	100		All benches	JT2	JT2 ESD

*The feature of this foot rest is the fluted exercise roller which revitalises the feet while working. The surface is corrugated to prevent slipping. Colour grey. Material polystyrene.

• = non stock item

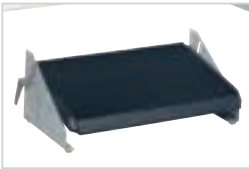

Footrest, floor

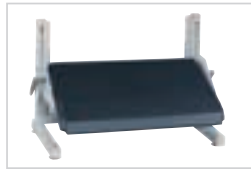

Footrest, floor, height adjustable

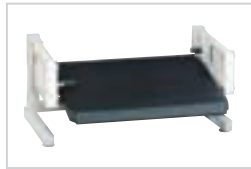

Footrest, floor, with gas action



Footrest JT2

ESD accessories

Earthing supplies

Name	Press button	Resistance	Code
1 Earthing box	3 x 10 mm	1 Mohm	J6603
2 Earth junction box, yellow			860 522-00
3 Earthing cable, black, 1,5 m	10 mm / M5 terminal	1 Mohm	860 520-00
4 Earthing cable 5 m	10 mm	1 Mohm	MK3040
5 Press stud	10 mm / female		PN3034

Wrist straps

Name	Press button	Resistance	Code
6 Adjustable wrist strap	7 mm	1 Mohm	R2216
7 Metal wrist strap	7 mm	1 Mohm	R2206

Wrist strap set includes wrist band and coiled cord. Earth lead with 1 megaohm resistor, length 3,6 m. Includes 7 mm press stud for connection to wrist strap and 10 mm press stud for connection to earthing point.

ESD mats

Name	Size W x D mm	Code
8 ESD Ergo floor mat	950 x 650	852 880-00
9 Bench top ESD-mats*	1,22 x 10,00 m (12,20 m ²)	PM157

Resistant to heat, solder flux, most chemicals and solvents. The ESD mats are to EN 61340-5-1 standards. Abraded non slip underside. Does not contain PVC. Supplied by the metre or on rolls. Colour: platinum grey. Resistance surface to ground: $7,5 \times 10^5 - 10^7$ ohm.

ESD-flooring LM 9500

Name	Roll size m	Resistance	Code
10 ESD-flooring	1,5 x 25	100K ohm	LM9500

Dissipative, hard wearing vinyl flooring requiring permanent on site installation. Supplied by the metre or on rolls. Accessories: Press stud and earthing cable. Colour: grey.





Lighting





Lighting ergonomics

When designing workstations and their lighting, we observe the recommendations of the EN 12464-1 standard on indoor workplace lighting. These recommendations apply mainly to the actual workstation and its immediate surroundings. The conditions set by the standard must be met in every location where the workstation could be placed. This becomes possible only with adequate, ambient lighting or quality workstation lighting, the latter often being the more cost-efficient solution.

When designing the workstation lighting, the requirements of the work are determined first. A task that demands a good eye for detail usually calls for a spotlight. If the viewed object is square, at least two lights are necessary, in order to remove shadows. If the viewed object is a level surface, it can be illuminated with one long fluorescent lamp – though it is important to remember to direct any reflections away from the user.

Optical ergonomics requires optimised conditions

Optical ergonomics relates to optimal viewing conditions; where the work performed does not unduly stress the eyes, even when working constantly over long periods of time. This requires the viewed object, such as a piece of equipment being assembled, to be at a suitable distance and direction, in order to keep eye movements at an acceptable level and ensure that the details can be seen without problems.

Another important requirement is adequate and glare-free lighting. In particular, poor viewing conditions affect presbyopic people (on average above 45 years of age) whose closest possible viewing-point is at a distance of around 50 cm. If the employee uses reading glasses at work, the position of the viewed object and the lighting require some additional attention.

When optical ergonomics have been integrated in the environment and the working position is well adjusted, you can expect to save time and money due to fewer absences and decreased stress.

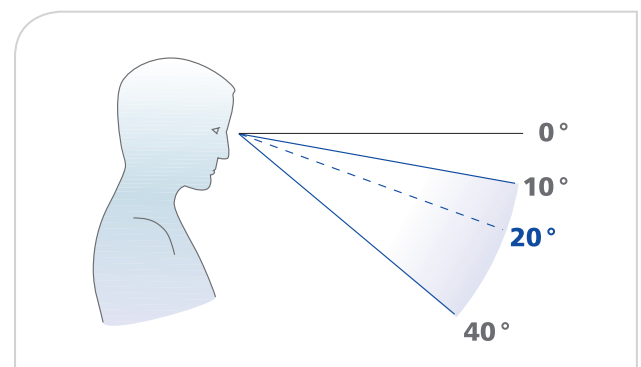

Optical ergonomics requires the viewed object to be at a suitable distance and direction, in order to keep eye movements at an acceptable level



LED magnifying task light

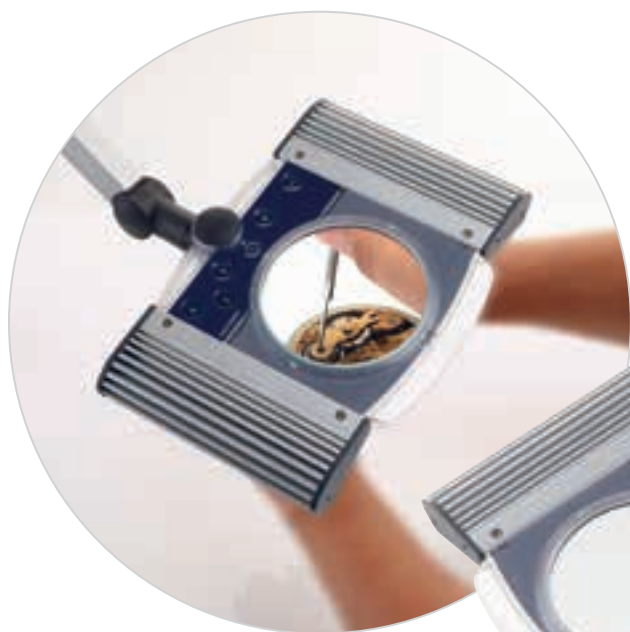

The magnifying task light is suitable for precise work for professionals in industry, research and development, laboratories, the medical profession, precision crafts, beauty clinics, the visually impaired etc.

Magnifying light ZL3

The new technology LED light creates the same amount of bright, flicker free light as a comparative fluorescent light but saves up to 75% electricity. The light has a 3 dioptre magnifying lense and an easy to use multi joint arm to be connected to a bench top.

Light is produced by 6 powerful LED's that can be adjusted according to needs; the left and right sides can be independently adjusted in steps. The light has a last-setting memory and the original settings can be reset. Environmentally friendly and long life LED's do not flicker or react to bumps and vibrations.

Name	Width mm	Lamp power	Code
Magnifying light	310	18 W	ZL3

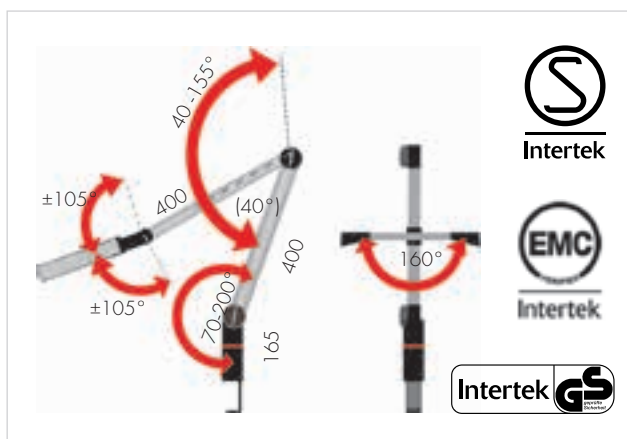

Distance 20 cm

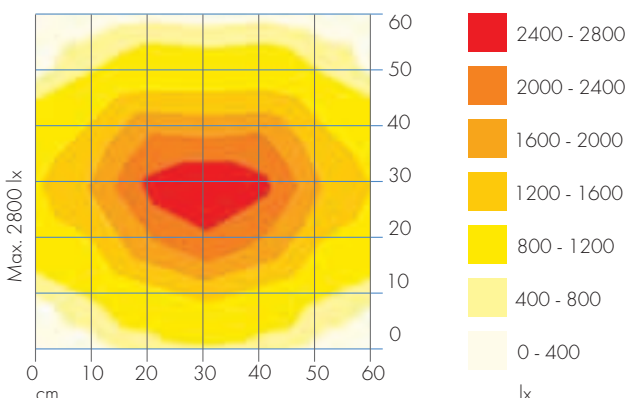

Distance 50 cm

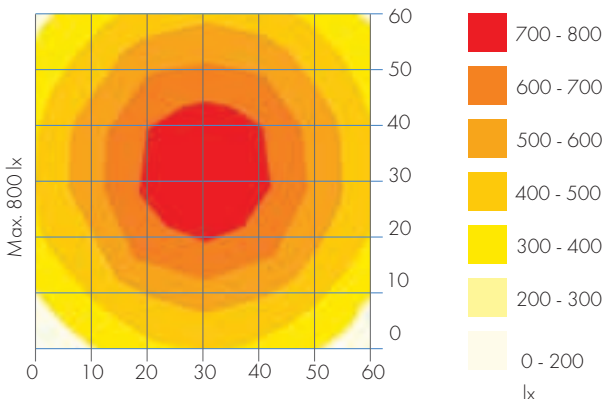

Graph of light intensity

Work surface dimensions: 60 x 60 cm. Distance of light from surface: 20 cm and 50 cm. Unit of measure: lux (lx). The higher the number, the stronger the light.



Lighting units

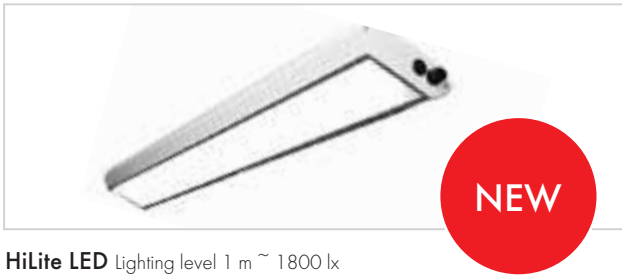

HiLite LED Lighting level 1 m ~ 1800 lx

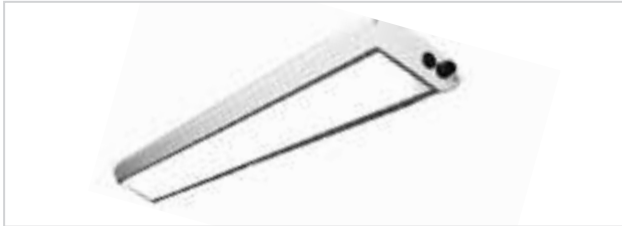

HiLite 54 Lighting level 1 m ~ 1350 lx



ProLite 28 Lighting level 1 m ~ 750 lx



Satellite 36 Lighting level 1 m ~ 800 lx



Task Light Lighting level 1 m ~ 400 lx

HiLite LED lamp is a top model representing state-of-the-art technology. The lamp has an excellent price-quality ratio, since it consumes little energy and consequently has a long service life. The HiLite LED is particularly suited to lighting tasks that require precision, such as assembly and inspection.

HiLite 54 is a powerful workbench light for the precise illumination of tasks that require high accuracy, such as electronics assembly, fine mechanical assembly, laboratories and testing.

ProLite 28 is a standard light for workbenches where good general lighting is required but high accuracy is not necessary, for example packing stations.

Satellite 36 is a side light designed to illuminate areas not reached by general lighting.

Task Light is an adjustable spotlight for tasks that require high accuracy, for example electronics repair and fine detailed mechanical work.

Name	Width mm	Lamp power	Suitability	Code
HiLite LED	1230	LED	all benches	861 956-00
HiLite 54*	1230	54 W	all benches	861 954-00
ProLite 28*	1230	28 W	all benches	861 928-00
Satellite 36*	500	36 W	Concept and TP benches	861 936-00
Task light	485	36 W	Concept and TP benches	860 181-35

* equipped with an electronic starter

Apart from task light luminaires can be mounted on all lamp mounts produced by Treston Group (WB: support bracket HSB, page 24 / Concept and TP: light and balancer rail, page 31 / TPH: tool and lighting support KT, page 46).

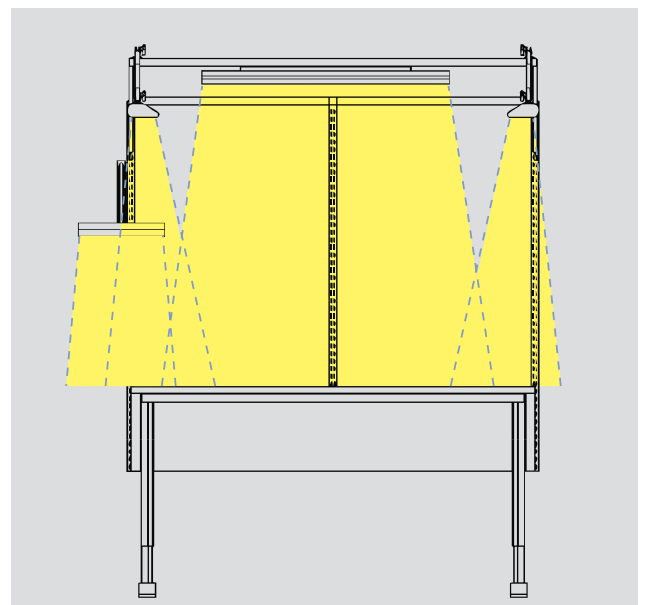

Optical ergonomics require adequate and glare-free lighting



Overlight OL 254 D



Sidelight SL 224

Overlight OL 254 and sidelight SL 224 are suitable for use with moving machinery giving asymmetric lighting with minimal shadow. (Flicker free tubes ensure that rotating objects will not appear to be stationary, a common optical effect when standard fluorescent tubes are used.) Silver grey anodized aluminium frame with an anti-dazzle screen. Angle continuously adjustable. With own switch and 3 m cable. The lighting units are isolated from the workbench.

Name	Width mm	Lamp power	Suitability	Code
Overlight OL254	1200	54 W	all benches	OL254
Overlight with dimmer OL254 D	1200	54 W	all benches	OL254 D
Sidelight SL224	590	24 W	WB and TPH benches	SL224

Overlights can be mounted on all lamp mounts produced by Treston Group (WB: support bracket HSB, page 24 /Concept and TP: light and balancer rail, page 31 / TPH: tool and lighting support KT, page 46).

Mounting kit SL-HKC required for use of sidelight with TPH benches; ordered separately.

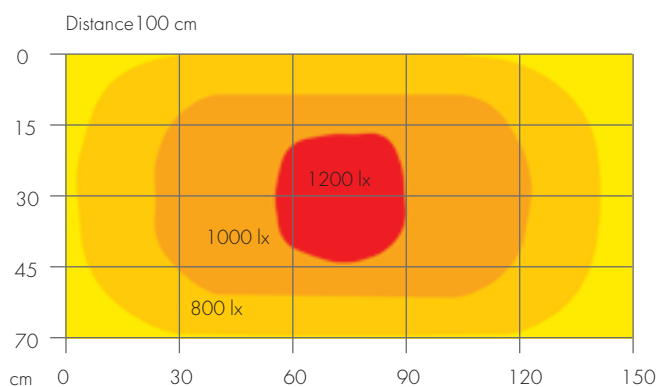

Graph of light intensity

Light intensity (lux) is tested on a horizontal worktop using the OL 254. The diagram below shows the results. Worktop size is 700 x 1500 mm, height of light unit above worktop is 1000 mm. The lux (lx) is the SI unit of illuminance and luminous emittance measuring luminous power per area.



Chairs





Chairs that are not only ergonomic but also stylish

The chair is a very important part of the ergonomics of a workstation. Even if the workstation is designed according to all the rules of ergonomics, a bad chair can destroy the final result. An ergonomic chair and a well-designed workstation make working productive and comfortable.

Upholstered chairs

Our upholstered chair range fulfils seating requirements from the production environment through to the office and meeting room. Optimum ergonomics improve workplace efficiency.

Industrial chairs

Durable industrial chairs constructed with a cushioned polyurethane seat and back that can be washed or steam cleaned. The chairs are very comfortable to sit on and offer excellent lumbar support. The grooves act as lines giving the chairs a new strong visual effect and style.

Ergonomic seating

The chair is a very important part of the ergonomics of a workstation. In order to get the best possible support in various working positions the chair must be adjusted correctly to every user.



Seat height



Seat tilt



Backrest tilt



Backrest height

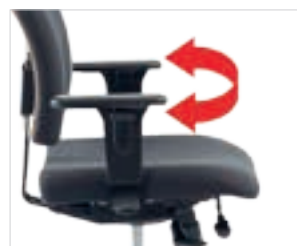

Armrests can be adjusted front- or backwards (X-series)





1. Task chair X30

- adjustment for seat height, seat tilt, backrest height and backrest tilt
- abrasion resistance: 100 000 Martindale (40 000 Martindale with ESD-textile)
- castors brake when unloaded
- arm rests as an option



2. Task chair X32

- two positions possible: normal sitting and half-sitting
- adjustment for seat height, seat tilt, backrest height and backrest tilt
- abrasion resistance: 100 000 Martindale (40 000 Martindale with ESD-textile)
- castors brake when unloaded
- arm rests as an option



3. Task chair X35

- adjustment for seat height, seat tilt, backrest height and backrest tilt
- abrasion resistance: 100 000 Martindale (40 000 Martindale with ESD-textile)
- floor glides and foot ring included
- arm rests as an option



4. Task chair X40

- synchronized mechanism for adjusting the seat and backrest tilt
- adjustment for seat height, seat depth, backrest height and backrest tilt
- abrasion resistance: >50 000 Martindale (40 000 Martindale with ESD-textile)
- castors brake when unloaded
- arm rests as an option



5. Task chair X40L

- as X40, but without head rest
- arm rests optional



6. Task chair S

- adjustment for seat height, backrest height and backrest tilt (+ seat tilt on ESD version)
- abrasion resistance: 60 000 Martindale (60 000 Martindale with ESD-textile)
- castors (no break)
- arm rests and higher gas spring as an option



ESD conductivity

ESD conductivity is in accordance with IEC 61340-5-1. Flammability class is EN1021/1-2

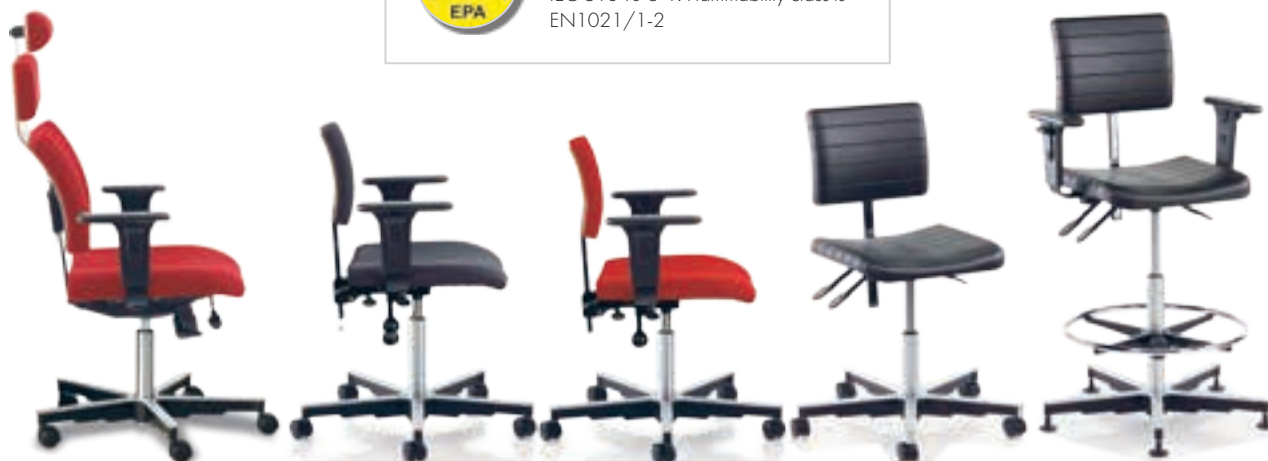



7. Polyurethane chair X20 PU

- seat and backrest are formed polyurethane
- adjustment for seat height, seat tilt, backrest height and backrest tilt
- castors brake when unloaded
- arm rests as an option



8. Polyurethane chair X25 PU

- seat and backrest are formed polyurethane
- adjustment for seat height, seat tilt, backrest height and backrest tilt
- floor glides and foot ring included
- arm rests as an option



9. Stool X10 PU

- seat is formed polyurethane
- adjustment for seat height
- castors brake when unloaded



10. Stool X15 PU

- construction as X10, but slightly higher



11. Saddle chair

- freedom of movement with ergonomic sitting position
- adjustment for seat height, seat tilt
- abrasion resistance: >50 000 Martindale with ESD-textile
- castors (no break)



Blue textile



Red textile



Grey textile



Dark blue textile

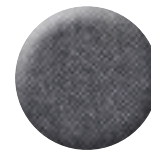

Grey ESD-textile



Black ESD-textile



1

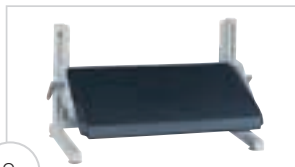

2



3



4

Footrests

Name	Size W x D mm	Height	Tilting	Code	Code ESD
1. Footrest, floor •	550 x 350	100	5-30		860 947-35
2. Footrest, floor, height adjustable	550 x 350	90-280	5-30		860 137-35
3. Footrest, floor, with gas action	550 x 350	90-260	5-30		860 224-35
4. Footrest JT2*	500 x 370	100		JT2	JT2 ESD

*The feature of this foot rest is the fluted exercise roller which revitalises the feet while working. The surface is corrugated to prevent slipping. Colour grey. Material polystyrene.

• = non stock item



Product	Height adjust	Seat size mm	Backrest size mm	Code	Code ESD
1 Task chair X30 B, blue	410-550	445 x 455	370 x 275	X30 B	
Task chair X30 R, red	410-550	445 x 455	370 x 275	X30 R	
Task chair X30 G, grey	410-550	445 x 455	370 x 275	X30 G	
Task chair X30 G ESD, grey	410-550	445 x 455	370 x 275		X30 G ESD
2 Task chair X32 B, blue •	450-650	445 x 455	370 x 275	X32 B	
Task chair X32 R, red •	450-650	445 x 455	370 x 275	X32 R	
Task chair X32 G, grey	450-650	445 x 455	370 x 275	X32 G	
Task chair X32 G ESD, grey	450-650	445 x 455	370 x 275		X32 G ESD
3 Task chair X35 B, blue	500-740	445 x 455	370 x 275	X35 B	
Task chair X35 R, red •	500-740	445 x 455	370 x 275	X35 R	
Task chair X35 G, grey •	500-740	445 x 455	370 x 275	X35 G	
Task chair X35 G ESD, grey •	500-740	445 x 455	370 x 275		X35 G ESD
4 Task chair X40 B, dark blue	420-560	475 x 455	510 x 430	X40 B	
Task chair X40 R, red	420-560	475 x 455	510 x 430	X40 R	
Task chair X40 G, grey	420-560	475 x 455	510 x 430	X40 G	
Task chair X40 G ESD, grey	420-560	475 x 455	510 x 430		X40 G ESD
Task chair X40 BL ESD, black	420-560	475 x 455	510 x 430		X40 BL ESD
5 Task chair X40L B, dark blue •	420-560	475 x 455	510 x 430	X40L B	
Task chair X40L R, red •	420-560	475 x 455	510 x 430	X40L R	
Task chair X40L G, grey •	420-560	475 x 455	510 x 430	X40L G	
Task chair X40L G ESD, grey •	420-560	475 x 455	510 x 430		X40L G ESD
Task chair X40L BL ESD, black •	420-560	475 x 455	510 x 430		X40L BL ESD
6 Task chair S, grey	400-550	480 x 470	420 x 380	862 013-00	
Task chair S ESD, black	400-550	480 x 470	420 x 380		862 001-00
7 Polyurethane chair X20 PU, black	400-540	370 x 425	350 x 265	X20 PU	
Polyurethane chair X20 PU ESD, black	400-540	370 x 425	350 x 265		X20 PU ESD
8 Polyurethane chair X25 PU, black	490-730	370 x 425	350 x 265	X25 PU	
Polyurethane chair X25 PU ESD, black	490-730	370 x 425	350 x 265		X25 PU ESD
9 Stool X10 PU, black	370-510	Ø 350		X10 PU	
Stool X10 PU ESD, black	370-510	Ø 350			X10 PU ESD
10 Stool X15 PU, black	490-730	Ø 350		X15 PU	
Stool X15 PU ESD, black	490-730	Ø 350			X15 PU ESD
11 Saddle chair B, blue	575-820			Saddle B	
Saddle chair ESD, blue	550-730	420 x 350			862010-00
Saddle chair G ESD, grey	575-820				Saddle G ESD
Saddle chair AL ESD, black (artificial leather)	575-820				Saddle AL ESD
Saddle chair AL Antib, black (artificial leather)	575-820			Saddle AL Antib	
Saddle chair L, black (leather)	575-820				Saddle L

• = non stock item

Accessories for chairs

Product	Height adjust mm	Dimension mm	Compatibility	Code	Code ESD
Arm rests X-series	140-220		X-series	AR	
Arm rests X-series ESD	140-220		X-series, ESD		AR ESD
Arm rests, task chair S	160-220		Task chair S	862 007-00	
Arm rests ESD, task chair S	160-220		Task chair S, ESD		862 006-00
Gas lift	400-540/410-550/420-560		X20 PU/X30/X40	4046	
Gas lift	450-650		X32	4062	
Gas lift	500-740		X35/X25 PU	4047	
Gas lift	370-510		X10	4046	
Gas lift, black	530-720		Task chair S	862 008-00	
Gas lift, ESD, chrome	530-720		Task chair S, ESD		862 009-00
Foot ring, chrome			X35, X25PU	8766	
Foot ring, chrome		Ø 440	Task chair S	831 190-50	
Black - swivelling twin castor for soft floors (brake unloaded), standard in X10 - X30		Ø 50	all chairs	4044	
Black/grey - SOFT swivelling twin castor for hard floors (brake unloaded), standard in X40		Ø 50	all chairs	4061	
Black - ESD swivelling twin castor for ESD floors (brake unloaded), standard in X10 - X40 ESD		Ø 50	all chairs		4045
Black/grey - ESD SOFT swivelling twin castor for ESD floors (brake unloaded), TO ORDER		Ø 50	all chairs		9692
Black/grey - ESD SOFT swivelling twin castor for ESD floors (brake loaded), TO ORDER		Ø 50	all chairs		9722
Crome swivelling twin castor for soft floor (brake loaded), TO ORDER		Ø 50	all chairs	9723	
Floor glide, standard in X25 PU, X35		Ø 14/50, h: 39,5		4043	4060
High ESD floor glide, TO ORDER		Ø 36/50, h: 59,5	X10, X20, X30		4088



Trolleys





Freedom of mobility with trolleys

Increased productivity with mobility

Work is not always confined to a single workstation and tools must be moved around accordingly. Lightweight trolleys are ideal for this situation, significantly increasing productivity up to 30%.

The trolleys provide extra work or storage space and can be used, for example, to transport various items, to store measuring units and keep a buffer stock on a production line.

Each task is different and requires dedicated tools. Due to their modularity and versatile accessory components, trolleys are easy to design and adapt to suit a multitude of users and applications.





Universal trolley WTR

Most often combined with WB workstations to provide extra storage space. A good adjustable PC station, measuring station or mobile storage, best suitable for moving equipment around the workstation.



Multi trolley

With three widths and two heights available this trolley is suitable for a wide range of needs. The sturdy shelves can be adjusted and tilted, making it easy to arrange different types of equipment, even heavy loads.



Basic trolley

This trolley can be equipped with shelves, tops and other accessories to fit any application, such as transportation or tool storage.



Adjustable trolley TRTA

For general use wherever a good transportation and storage solution is needed. Two or four shelves available; height of the shelves can be adjusted. Mesh panels can be installed at the ends or on the sides. Also a SMD reel holder version available.



Mobile workstation MLC

An ergonomic and versatile tool with key qualities such as light weight, small size and excellent mobility. Used wherever a laptop is needed on the go.



Storage trolley

Simple solution for mobile storage. The shelves are fitted with rubber mats and the middle shelf is adjustable.



Ergo trolley

Most often combined with Concept workstations to provide extra work and storage space. Can be equipped with a lower shelf, available separately.



SAP trolley

Most often combined with TP workstations to provide extra workspace. Can be equipped with a lower shelf, available separately.



CTR trolley

Most often combined with WB workstations to provide extra workspace. Lower shelf is integrated.



Universal trolley WTR



A good quality, versatile trolley, PC-station, measuring station or mobile storage trolley. Modern industrial design.

The standard trolley has 3 shelves (TS 605), size 650 x 530 mm. Height adjustment of shelves is by allen-key. The vertical profiles are of aluminium. Frames are of epoxy powder coated steel: light grey RAL 7035. The worktops are of 25 mm laminated particle board. Four swivel castors (Ø 125 mm) two of which have brakes, overall height of castor 141 mm.

Universal trolley WTR

Name	Size W x D x H mm	Max load kg	Code	Code ESD
1. Universal trolley	660 x 650 x 1415	150	WTR140	WTR140 ESD
2. Extra shelf	530 x 650	50	TS605	TS605 ESD
3. Adjustable shelf*	530 x 650	50	TAS605	TAS605 ESD
4. Bin profile	Length 525		BP50	BP50 ESD
5. Power channel WJK 40**	Length 470 mm		WJK40	WJK40

*Continuous adjustment for depth, height and angle.

** May be fitted with a choice of components, ordered separately. All meet with CE requirements. 3 m cable is included.

**COMPONENTS FOR POWER CHANNEL WJK 40

E1 Double socket (max. 5 pcs/1 cable)	E6 Data connector/shielded for Cat.6 cable
E2 Switch	E7 Data connector/without screen for Cat.5 cable
E3 Automatic fuse 10 A	E8 Pneumatic, quick coupling 3/8"
E4 Automatic fuse/earth leakage switch 10 A/30 mA	
E5 Emergency-stop-switch	





Multi trolley

Multi trolleys provide an ergonomic mobile workstation. Multi trolleys are available in three different widths: M500, M750 and M900. This means that all our module-sized accessories can be used with the trolleys.

The sturdy shelves can be height-adjusted and tilted. They are also equipped with borders and rubber mats, which keep the load in place.

Multi trolleys support heavy loads, but they are easy to move as well, making it simple to transport heavy equipment, such as measuring units. They are equipped with four swivel castors (Ø 100 mm), two of which have brakes.

Multi trolleys

Name	Module	Code	Code ESD
Multi trolley 1	M500	C 721 41 001 •	C 721 35 001 •
Multi trolley 1	M750	C 721 41 002 •	C 721 35 002 •
Multi trolley 1	M900	C 721 41 003 •	C 721 35 003 •
Multi trolley 2	M500	C 722 41 001	C 722 35 001
Multi trolley 2	M750	C 722 41 002	C 722 35 002
Multi trolley 2	M900	C 722 41 003	C 722 35 003

• = non stock item



Multi trolley 2

Multi trolley 1

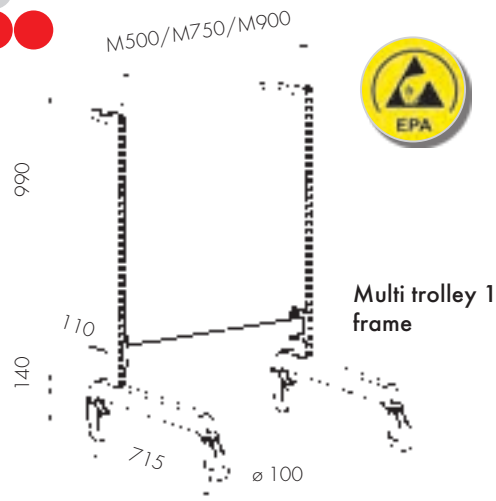

Multi trolley 1 frame

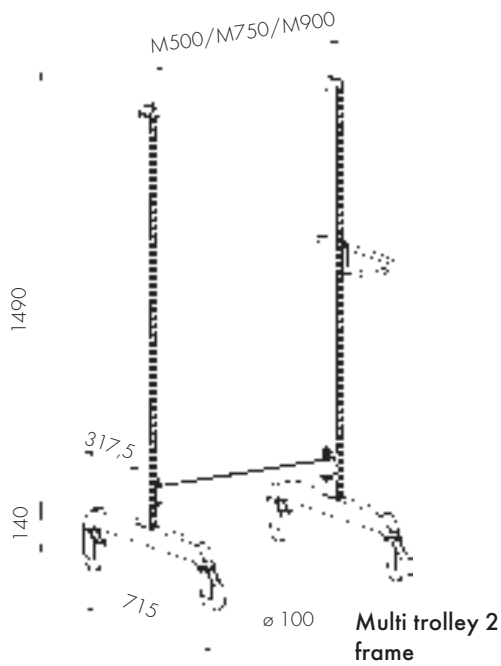

Multi trolley 2 frame

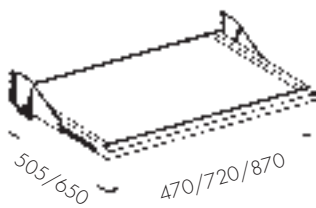

Multi trolley frame

Name	Module	Size W x D x H mm	Max load kg	Code	Code ESD
Multi trolley 1 frame	M500	530 x 715 x 1130	300	860 812-41	860 812-35
Multi trolley 2 frame	M500	530 x 715 x 1630	300	860 818-41	860 818-35
Multi trolley 1 frame	M750	780 x 715 x 1130	300	860 154-41	860 154-35
Multi trolley 2 frame	M750	780 x 715 x 1630	300	860 156-41	860 156-35
Multi trolley 1 frame	M900	935 x 715 x 1130	300	860 155-41	860 155-35
Multi trolley 2 frame	M900	935 x 715 x 1630	300	860 157-41	860 157-35

Bottom shelf

Name	Module	Size W x D mm	Max load kg	Code	Code ESD
Bottom shelf*	M500	470 x 505	100	860 846-41	860 846-35
Bottom shelf	M500	470 x 650	100	860 847-41	860 847-35
Bottom shelf*	M750	720 x 505	100	860 057-41	860 057-35
Bottom shelf	M750	720 x 650	100	860 067-41	860 067-35
Bottom shelf*	M900	870 x 505	100	860 059-41	860 059-35
Bottom shelf	M900	870 x 650	100	860 069-41	860 069-35

*Compatible only with Multi trolley 1.

Adjustable shelves are equipped with an ESD mat (35) or rubber mat (41).

Adjustable shelf for trolleys

Name	Module	Size W x D mm	Max load kg	Code ESD
Adjustable shelf	M500	470 x 505	100	921 35 001
Adjustable shelf	M500	470 x 650	100	921 35 002
Adjustable shelf	M750	720 x 505	100	921 35 005
Adjustable shelf	M750	720 x 650	100	921 35 006
Adjustable shelf	M900	870 x 505	100	921 35 009
Adjustable shelf	M900	870 x 650	100	921 35 010

Adjustable shelves are equipped with an ESD mat (35) or rubber mat (41).

Adjustable shelf, stepless depth adjustment

Name	Module	Size W x D mm	Max load kg	Code ESD
Adjustable shelf, stepless depth adjustment	M500	470 x 505	50	921 35 003
Adjustable shelf, stepless depth adjustment	M500	470 x 650	50	921 35 004
Adjustable shelf, stepless depth adjustment	M750	720 x 505	50	921 35 007
Adjustable shelf, stepless depth adjustment	M750	720 x 650	50	921 35 008
Adjustable shelf, stepless depth adjustment	M900	870 x 505	50	921 35 011
Adjustable shelf, stepless depth adjustment	M900	870 x 650	50	921 35 012

Adjustable shelves are equipped with an ESD mat (35) or rubber mat (41).



Modular size

The modular (M) size refers to the distance between two upright tubes from the middle of the tube. The modular size is used to find the appropriate accessories.

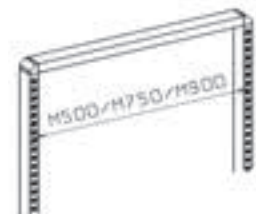

Basic trolley



Equip your trolleys with shelves, tops and other accessories to fit any application, such as transportation or tool storage. All trolleys are equipped with four swivel castors (Ø 125 mm), two of which have brakes. The basic trolley can be combined with all the M750 accessories.

Basic trolleys

Name	Size W x D x H mm	Max load kg	Code
Basic trolley 1	800 x 715 x 1625	350	C 740 35 101
Basic trolley 2	800 x 715 x 1625	350	C 740 07 102
Basic trolley 3	800 x 715 x 1625	350	C 740 41 003
Basic trolley 4	800 x 715 x 1625	350	C 740 07 004
Basic trolley 5	800 x 715 x 1625	350	C 740 41 105
Basic trolley frame	800 x 715 x 1625	350	C 740 41 000

Basic trolley accessories

Name	Size W x D x H mm	Max load kg	Code
Bottom shelf with rubber mat	720 x 560 x 32	150	852 719-41
Bottom shelf with HDPE plastic covering	720 x 560 x 32	150	852 683-41
Shelf with rubber mat*	720 x 560 x 32	150	852 720-41
Shelf with HDPE plastic covering*	720 x 560 x 32	150	852 684-41
Steel shelf*	720 x 560 x 32	150	852 685-35
Steel shelf	720 x 560 x 32	150	852 665-35
Extendable shelf*	720 x 580 x 33	50	852 687-35
Wash basket L-300	380 x 302 x 110	20	839 116-51
Waste basket			839 159-00
Waste basket holder			835 773-35
Paper roll holder	Roll dimensions max: width 240 mm, Ø 230 mm)		860 310-35

Trolleys can be combined with all the M750 accessories. For perforated panels, see p. 105, for R-hooks, see p. 106.

*including brackets



Basic trolley 1



Basic trolley 2



Basic trolley 3



Basic trolley 4



Basic trolley 5

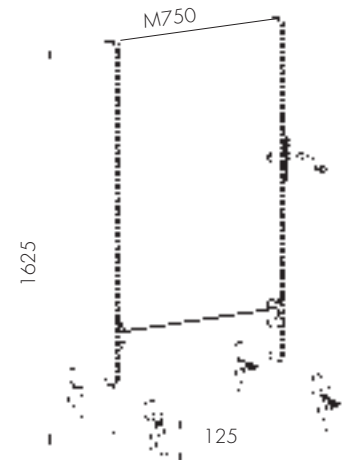

Basic trolley frame



Adjustable trolley TRTA



For general use in workshops, offices, production areas and hospitals. Epoxy powder coated RAL 7035 ESD shelves, depth 28 mm. All shelves are individually adjustable. The structure is light but sturdy. The end-frames of the trolley are made of round, powder coated steel tube (25 mm). Four turning castors (Ø 125 mm), two of which have brakes.

Adjustable trolley TRTA

Name	Size W x D x H mm	Shelf size W x D mm	Max load kg	Code	Code ESD
2-shelf trolley*	890 x 530 x 1020	800 x 430	150	TRTA4082	TRTA4082 ESD
2-shelf trolley*	1090 x 530 x 1020	1000 x 430	150	TRTA4102	TRTA4102 ESD
2-shelf trolley*	890 x 630 x 1020	800 x 530	150	TRTA5082	TRTA5082 ESD
2-shelf trolley*	1090 x 630 x 1020	1000 x 530	150	TRTA5102	TRTA5102 ESD
4-shelf trolley**	1090 x 530 x 1515	1000 x 430	300	TRTA4104	TRTA4104 ESD
4-shelf trolley**	1090 x 630 x 1515	1000 x 530	300	TRTA5104	TRTA5104 ESD

* Shelf adjustments between 200-770 mm

** Shelf adjustments between 215-1340 mm



Extra shelves TRHA

Name	Shelf size W x D mm	Max load kg	Code	Code ESD
Extra shelf	800 x 430	50	TRHA408	TRHA408 ESD
Extra shelf	1000 x 430	50	TRHA410	TRHA410 ESD
Extra shelf	800 x 530	50	TRHA508	TRHA508 ESD
Extra shelf	1000 x 530	50	TRHA510	TRHA510 ESD

End mesh panels NET2

Name	Size W x D mm	Set	Code	Code ESD
End mesh panel	604 x 364	Incl. 2 panels	NET2	NET2 ESD

The mesh panels can be installed at the ends of the trolley or on the sides. An angle bracket is set on the edge of the upper and lower shelf and the mesh is screwed into place. The 4-shelf trolley can hold 2 mesh panels on top of each other.

Document holder DSA4

Name	Size	Code	Code ESD
Document holder	A4	DSA4	DSA4 ESD

Semiconductive epoxy powder coated steel. Includes two magnets.



Document holder



Reel holder trolley RRT

The adjustable reel holder trolley is compatible with SMD reels, and suitable for transport and stocking of them. All parts are powder coated steel, RAL 7035 ESD. The trolley has four perforated steel shelves, depth 28 mm. All shelves are individually adjustable.

The reel racks that fit into the shelves are to be ordered separately. The structure is light but sturdy. The end-frames of the trolley are made of round, powder coated steel tube (25 mm). Four turning castors (Ø 125 mm), two of which have brakes. The load capacity of one shelf is 50 kg, and the load capacity of the trolley is 200 kg.

Reel holder trolley RRT

Name	Size W x D x H mm	Max load kg	Code ESD
1. Reel holder trolley	1100 x 530 x 1780	200	RRT ESD
2. Reel rack	960 x 426 x 254	50	RR ESD
3. Document holder	A4		DSA4 ESD

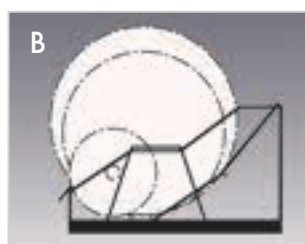
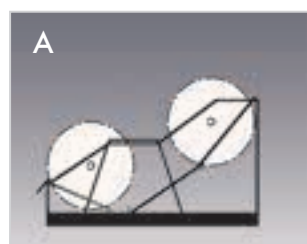

In picture A: Side view of spools and reel racks. The capacity of one rack is 30 fixed compartments for 7" spools of 60 mm width.

In picture B: Side view of spools and reel racks. The capacity of one rack is 15 fixed compartments for 13" and 15" spools of 60 mm width.





Mobile workstation MLC



A laptop computer can be used either on the work surface or housed in the enclosure underneath. In the latter case only the screen is visible and a separate keyboard can be kept on a keyboard and mouse tray (optional accessory) keeping the worksurface clear. The worksurface is surrounded by a Euro rail for mounting accessories.

Mobile workstation MLC

Name	Size W x D x H mm	Code
Mobile workstation	590 x 540 x 800-1200	MLC405 G
Top size 520 x 370 mm.		



Mobile workstation accessories

Name		Code
1. Keyboard and mouse tray	210 x 620 mm. Equipped with a wrist support.	KH620
2. Binder mount	Fits a single 75 mm wide binder.	FH1
3. Binder mount	Fits three 75 mm wide binders.	FH3
4. Accessories basket	Blue bin, int. dim. 230 x 155 x 140 mm	AB1930
5. LCD bracket	Load capacity 15 kg, mounting holes 75 x 75 / 100 x 100 apart	MH
6. LCD swivel arm	For the attachment of MH and MY supports. Max 22" screen.	MS
7. Tablet bracket	For 7-10" tablets. Requires either an MH, MA or MA2 swivel arm.	MY



Trolleys for additional workspace

Storage trolley is an easy solution for mobile storage, the storage trolley has an adjustable middle shelf, and the shelves are fitted with standard rubber mats.

Ergo trolley provides extra workspace for the Concept workbench. Lower shelf is available separately. Height adjustment with allen key between 650-900 mm.

SAP trolley provides extra workspace for the TP workbench. Lower shelf is available separately. Height adjustment with allen key between 650-900 mm.

CTR trolley provides extra workspace for the WB workbench. Lower shelf is integrated. Height adjustment with allen key between 690-990 mm.



Trolleys for additional workspace

Name	Size W x D x H mm	Max load kg	Code	Code ESD
1. Storage trolley	650 x 450 x 775	3 x 30	852 773-41	852 773-35
2. Ergo trolley	750 x 500 x 650-900	150	-	860 422-35
Lower shelf for Ergo trolley	595 x 480	-	-	860 425-35
3. SAP trolley	700 x 500	150	SAP507	SAP507 ESD
SAP trolley	1000 x 700	150	SAP710	SAP710 ESD
SAP trolley	1500 x 700	150	SAP715	SAP715 ESD
Lower shelf for SAP trolley	700 x 500	40	AT507	AT507 ESD
Lower shelf for SAP trolley	1000 x 700	40	AT710	AT710 ESD
Handle for SAP trolley	depth 500		PUSH50	PUSH50
Handle for SAP trolley	depth 700		PUSH70	PUSH70
4. CTR trolley	700 x 500	75 / shelf	CTR705	CTR705 ESD

All the light-duty trolleys are equipped with four swivel castors (ø 100 mm), two of which have brakes. ESD versions are also available.



Storage trolley



Ergo trolley



SAP trolley



CTR trolley



Drawer units





Versatile drawer units

Since work is not always performed in the same place, we provide a comprehensive range of different drawer units for a variety of purposes. You can fix any drawer unit from the same series under a worktop or on a plinth, or equip them with castors to take along to your next workstation.

Efficient storage and control

Our drawer units are great for storing tools and supplies. It is surprising how much time is spent finding tools and other items if they are not stored systematically. The versatile interior combinations of our drawer units guarantee that your supplies are always at hand and in good order.

A comprehensive range of drawer units

We promise that you will find a drawer unit that meets your requirements in our comprehensive range. You can choose from several different heights and drawer and interior combinations. We have selected some combinations for this brochure. For more options, please contact: sales@trestongroup.com.

Drawer units for light loads

These drawer units are designed for storing lightweight items, for example in a testing laboratory or in an office environment.





Light steel cabinet LMC

Drawer units 30 and 35

These steel cabinets are an ideal way of providing individual secure storage for your staff. Drawers are mounted on telescopic ball race slides. Four cabinet sizes, including one drawer/cupboard combination.

These drawer units are fastened under a workbench to provide storage space. Choose from single drawer, two drawers or drawer cabinet. If additional drawers are needed, they can be easily attached to each other. The drawers can be locked to protect the contents.



Drawer unit 45

Drawer unit 75

Choose from two frame heights: 56 or 66 cm, with a plinth for a stand alone solution or with castors for a trolley version. The drawer unit 45 can also be attached under the worktop. All the drawer units have central locking.

Choose from two frame heights: 56 or 66 cm, with a plinth for the stand alone solution or with castors for a trolley version. All the drawer units have central locking.



Three-level locking system

The majority of our drawer units and cabinets can be equipped with a three-level locking system. This allows both serialisations of individual and identical locks. Contact your Treston Group representative for additional information. The locking services are always specified for the order.

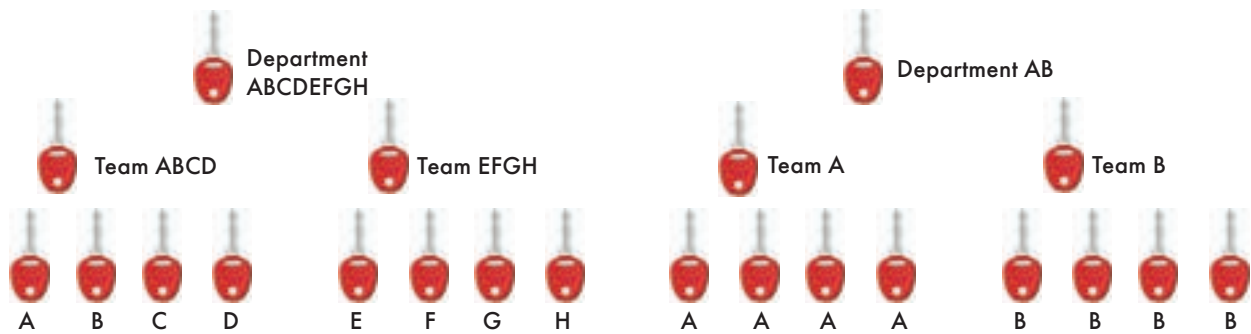

Serialisation of individual locks

Each drawer or cabinet has an individual lock in a production unit, but a master key opens all the locks of the unit. The master keys can also be serialised and the third-level key opens all the drawers and cabinets of all the production units.

Serialisation of identical locks

Each team member needs only one key to access all the drawers and cabinets in a production unit. A master key opens all the drawers and cabinets of all the production units and can also be serialised.





Light steel cabinet LMC

These steel cabinets are an ideal way of providing individual secure storage for your staff. Drawers are mounted on telescopic ball race slides. Four cabinet sizes, including one drawer/cupboard combination. These cabinets suit

any Treston Group workbenches. The cabinet frames are epoxy powder coated steel; drawer fronts are composite board with aluminium handles. Colour light grey, RAL 7035. Mount on benches with brackets (included).

Suitable for WB/TP workbenches and SAP710/SAP715/WTR trolleys



Light steel cabinet, load capacity 15 kg/drawer

Code	LMC01	LMC02	LMC04	LMC04D
Code ESD	LMC01 ESD	LMC02 ESD	LMC04 ESD	LMC04D ESD
Outer dims W x D x H mm	370 x 460 x 140	370 x 460 x 245	370 x 460 x 455	370 x 460 x 455
Includes drawers (outer height mm)	1 x 100	2 x 100	4 x 100	1 x 100 + cupboard, height 300 mm, open to right

Internal drawer dimensions: 278 x 438 x 75

Cover LMCK2

Description	Code
Needed for mounting cabinets to WB benches and WTR trolley.	LMCK2

Drawer units 30 and 35

These drawer units are fastened under a workbench to provide storage space. Choose from single drawer, two drawers or drawer cabinet. If additional drawers are

needed, they can be easily attached to each other. The drawers can be locked to protect the contents.

Drawer cabinet 35/47 is suitable for storing upright folders.



Drawer units 30 and 35, load capacity 10 kg/drawer

	30/15	30/22	35/47
Code	859 330-35	859 340-35	860 972-35
Outer dims W x D x H mm	300 x 454 x 150	300 x 454 x 220	350 x 470 x 470
Includes drawers (outer height mm)	1 x 100	2 x 100	1 x 100 + cupboard, height

Internal drawer dimensions: 255 x 400 x 120 / 300 x 400 x 70

Fastening sets for drawer units 30 and 35 The fastening set should be selected according to the type of the bench.

Depth	600 mm	700 mm	750 mm	900 mm
Concept workbench	860 931-35	-	860 930-35	860 239-35
Concept workbench with crank	-	-	860 930-35	-
TP workbench	-	855 054-35	-	855 054-35

Fastening set for the Concept motor bench (all drawer units) 854 463-35. Not adapted to Concept hand crank bench (depth 600 mm).



Drawer unit 45

Centrally locked high quality steel drawer units for storage of tools and small components. Mounted under workbenches with brackets. Also available with castors as a trolley version. Drawer units are epoxy powder coated in grey, RAL 7035. Central locking. Full width drawer handle in anodised aluminium. Smooth and quiet telescopic ball-race runners and clear opening of 375 mm. Load capacity 30 kg/drawer. Drawer size 380 x 500 mm.

All of our drawer units are also available as 100% extendable versions with a load-bearing capacity of 60 kg/drawer. Our drawer units are suitable for use in EPAs. Our mobile trolleys are available in both ESD and non-ESD versions.



Choose the drawer unit according to your needs; with castors, plinth or no plinth.

Load capacity 150 kg, 4 swivel castors (ø 100 mm), 2 with brakes. The trolley version comes with a rubber mat that stops items from sliding on the surface.

Combination name

45/56-1

Width Height Version



Bold font indicates that the product is available from stock.

Drawer unit 45/56, 75% opening, load capacity 30 kg/drawer

	L-45/56-1	L-45/56-2	L-45/56-3	L-45/56-4	L-45/56-7	L-45/56-11
Standard	606 35 001	606 35 002	606 35 003	606 35 004	606 35 007	606 35 0011
With plinth	606 35 011	606 35 012	606 35 013	606 35 014	606 35 017	606 35 0021
With castors	606 35 021	606 35 022	606 35 023	606 35 024	606 35 027	-
Height (mm) of the drawer	5 x 100	2 x 100 2 x 150	3 x 100 1 x 200	1 x 100 2 x 200	2 x 150 1 x 200	1 x 200 1 x 300

Internal drawer dimensions: 380 x 500 x 90/140/190 mm.

Drawer unit 45/66, 75% opening, load capacity 30 kg/drawer

	L-45/66-1	L-45/66-2	L-45/66-3	L-45/66-4	L-45/66-5	L-45/66-6	L-45/66-7
Standard	607 35 001	607 35 002	607 35 003	607 35 004	607 35 005	607 35 006	607 35 007
With plinth	607 35 011	607 35 012	607 35 013	607 35 014	607 35 015	607 35 016	607 35 017
With castors	607 35 021	607 35 022	607 35 023	607 35 024	607 35 025	607 35 026	607 35 027
Height (mm) of the drawer	6 x 100	3 x 100 2 x 150	1 x 100 2 x 150 1 x 200	4 x 150	4 x 100 1 x 200	2 x 100 2 x 200	3 x 200

Internal drawer dimensions: 380 x 500 x 90/140/190 mm.



Drawer unit 45/56, 100% opening, load capacity 60 kg/drawer

	45/56-1	45/56-2	45/56-3	45/56-4	45/56-7	45/56-10	45/56-11
Standard	606 35 101	606 35 102	606 35 103	606 35 104	606 35 107	606 35 110	606 35 111
With plinth	606 35 201	606 35 202	606 35 203	606 35 204	606 35 207	606 35 210	606 35 211
With castors	606 35 301	606 35 302	606 35 303	606 35 304	606 35 307	-	-
Height (mm) of the drawer	5 x 100 	2 x 100 2 x 150 	3 x 100 1 x 200 	1 x 100 2 x 200 	2 x 150 1 x 200 	2 x 100 1 x 300 	1 x 200 1 x 300

Internal drawer dimensions: 380 x 500 x 90/140/190/290 mm.

Drawer unit 45/66, 100% opening, load capacity 60 kg/drawer

	45/66-1	45/66-2	45/66-3	45/66-4	45/66-5	45/66-6	45/66-7
Standard	607 35 101	607 35 102	607 35 103	607 35 104	607 35 105	607 35 106	607 35 107
With plinth	607 35 201	607 35 202	607 35 203	607 35 204	607 35 205	607 35 206	607 35 207
With castors	607 35 301	607 35 302	607 35 303	607 35 304	607 35 305	607 35 306	607 35 307
Height (mm) of the drawer	6 x 100 	3 x 100 2 x 150 	1 x 100 2 x 150 1 x 200 	4 x 150 	4 x 100 1 x 200 	2 x 100 2 x 200 	3 x 200

Internal drawer dimensions: 380 x 500 x 90/140/190 mm.

Drawer unit 45/66, 100% opening, load capacity 60 kg/drawer

	45/66-12	45/66-13	45/66-14	45/66-15
Standard	607 35 112	607 35 113	607 35 114	607 35 115
With plinth	607 35 212	607 35 213	607 35 214	607 35 215
Height (mm) of the drawer	3 x 100 1 x 300 	2 x 150 1 x 300 	1 x 100 1 x 200 1 x 300 	2 x 300

Internal drawer dimensions: 380 x 500 x 90/140/190/290 mm.

Internal drawer dimensions mm	
Width 380	Depth 500
Outer height mm	Inner height mm
100	90
150	140
200	190
300	290

! Drawer units with castors are also available as non ESD-versions (code 41 instead of 35).



Cabinets include one bottom shelf and one adjustable shelf, shelf load capacity 50 kg.

Cabinet 45/56, door right

	w/o lock	with lock
Standard	606 35 105	606 35 108
With plinth	606 35 205	606 35 208
With castors	606 35 305	606 35 308

Cabinet 45/56, door left

	w/o lock	with lock
Standard	606 35 106	606 35 109
With plinth	606 35 206	606 35 209
With castors	606 35 306	606 35 309





Drawer cabinet 45/66, door right

	drawer 1 x 100	w/o lock	with lock
Standard		607 35 108	607 35 110
With plinth		607 35 208	607 35 210
With castors		607 35 308	607 35 310

Drawer cabinet 45/66, door left

	drawer 1 x 100	w/o lock	with lock
Standard		607 35 109	607 35 111
With plinth		607 35 209	607 35 211
With castors		607 35 309	607 35 311

Drawer units 45/14 and 45/26

Model	Opening	Load capacity kg / drawer	Outer dims W x D x H mm	Height (mm) of the drawer		Code
45/14-1	100%	60	450 x 520 x 140	1 x 100		603 35 001
L-45/14-1	75%	30	450 x 520 x 140	1 x 100		603 35 002
45/26-1	100%	60	450 x 520 x 260	2 x 100		604 35 001
L-45/26-1	75%	30	450 x 520 x 260	2 x 100		604 35 002

Internal drawer dimensions: 380 x 500 x 90 mm.



Fastening sets for drawer unit 45

The fastening set should be selected according to the type of the bench. For WB/TP benches brackets are included.

	600 mm	700 mm	750 mm	900 mm
Concept workbench	860 931-35	-	860 930-35	860 239-35

Fastening set for the Concept motor bench (all drawer units) 854 463-35. Not adapted to Concept handcrank bench or Concept motor bench (depth 600 mm).

For heavy loads we recommend adding a plinth or castors to the cabinet.

Cover

Description	Order no
Needed for mounting from-stock sortiment's drawers to WB benches.	855 060-35

Horizontal dividers

4 x horizontal divider	Order no
Drawer 45/100	872 982-35
Drawer 45/150 and 45/200	872 983-35

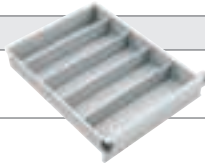

The maximum load capacity of 100% extendable drawers is 60 kg!

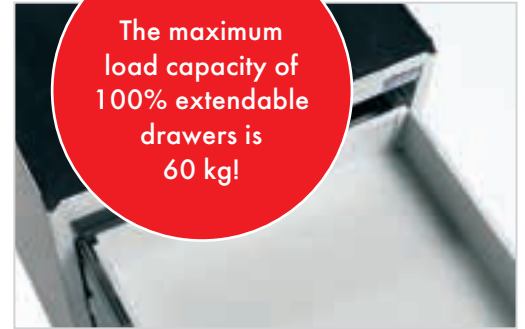

A fully extendable drawer is perfect for laboratory use, for example.

Combination name

45/56-1

Width Height Version

Drawer unit 75

Choose from two frame heights: 56 or 66 cm, with plinth for a stand alone solution or with castors for a trolley version. All the drawer units have central locking.



Trolley model: load capacity 150 kg, 4 swivel castors (ø 100 mm), 2 with brakes. The trolley version comes with a rubber mat that stops items from sliding on the surface.



Choose the drawer unit according to your needs; with castors, plinth or no plinth.











Cabinets include a bottom shelf and one adjustable shelf. Shelf load capacity 50 kg.



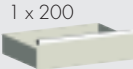









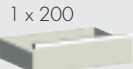

Drawer unit 75/56, 100 % opening, load capacity 60 kg/drawer

	75/56-1	75/56-2	75/56-3	75/56-4	75/56-7
Standard	608 35 101	608 35 102	608 35 103	608 35 104	608 35 107
With plinth	608 35 201	608 35 202	608 35 203	608 35 204	608 35 207
With castors	608 35 301	608 35 302	608 35 303	608 35 304	608 35 307
Height (mm) of the drawer	5 x 100 	2 x 100  2 x 150 	3 x 100  1 x 200 	1 x 100  2 x 200 	2 x 150  1 x 200 

Internal drawer dimensions: 670 x 500 x 90/140/190 mm.

Drawer unit 75/66, 100 % opening, load capacity 60 kg/drawer

	75/66-1	75/66-2	75/66-3	75/66-4	75/66-5	75/66-6	75/66-7
Standard	609 35 101	609 35 102	609 35 103	609 35 104	609 35 105	609 35 106	609 35 107
With plinth	609 35 201	609 35 202	609 35 203	609 35 204	609 35 205	609 35 206	609 35 207
With castors	609 35 301	609 35 302	609 35 303	609 35 304	609 35 305	609 35 306	609 35 307
Height (mm) of the drawer	6 x 100 	3 x 100  2 x 150 	1 x 100  2 x 150  1 x 200 	4 x 150 	4 x 100  1 x 200 	2 x 100  2 x 200 	3 x 200 

Internal drawer dimensions: 670 x 500 x 90/140/190 mm

Cabinet 75/56 double-door

	w/o lock	with lock
Standard	608 35 105	608 35 106
With plinth	608 35 205	608 35 206
With castors	608 35 305	608 35 306

! Drawer units with castors are also available as non ESD-versions (code 41 instead of 35).

Drawer cabinet 75/66 double-door

drawer 1 x 100	w/o lock	with lock
Standard	609 35 108	609 35 109
With plinth	609 35 208	609 35 209
With castors	609 35 308	609 35 309

Fastening sets for drawer unit 75

The fastening set should be selected according to the type of workbench

	600 mm	700 mm	750 mm	900 mm
Concept workbench	860 931-35	-	860 930-35	860 239-35
TP workbench	-	855 055-35	-	855 055-35

Fastening set for the Concept motor bench (all drawer units) 854 463-35. Not adapted to Concept handcrank bench or Concept motor bench (depth 600 mm).

For heavy loads we recommend adding a plinth or castors to the cabinet.

The maximum load capacity of 100% extendable drawers is 60 kg!



In the picture, the drawer unit 75/66 double door with a 100 mm drawer.

Horizontal dividers

4x horizontal divider	
Drawer 75/100	872 985-35
Drawer 75/150	872 986-35
Drawer 75/200	872 986-35

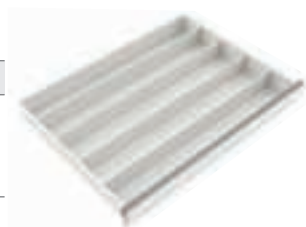

Vertical dividers

3x vertical divider	
Drawer 75/100	872 988-35
Drawer 75/150	872 989-35
Drawer 75/200	872 989-35





Shelves and cabinets





There's a place for each item

Shelving units and cabinets are an essential element in keeping the workplace tidy and in good order. Shelving units can also be used as room divider elements and are available with ESD protection.

Extended tool life

The service life and condition of tools can be significantly improved through their appropriate storage. They are stored in their own places, protected from dust and dirt, in a locked cabinet.

A versatile storage solution is created by using suitable accessories

An open shelf is not always the best way to store things. Tools, expensive equipment, and small items need another type of solution. Through using lockable drawers or adding doors and walls, an open shelving system is turned into a versatile storage solution. Drawers can be fitted with a variety of interior combinations, to suit the tools stored in them.

The Treston Group storage system is modifiable

Our storage system is built around the basic component, and extension parts, doors, screens, and other accessories can be added to create an efficient overall solution. In addition the shelf heights can easily be adjusted as needed. Even the load capacity can be increased by adding additional supports.

Treston Group industrial cabinets allow for a tidy, efficient working environment

No unnecessary time should be used looking for tools and materials. This interrupts work and causes stress. In a well organised cabinet, everything is where it should be.

A ready-assembled cabinet is easy to move to the most convenient location. There are adjustable glides underneath that make it easy to adjust the cabinet so that it stands straight on uneven surfaces. All M750 and accessories, such as shelves, drawer units, perforated panels, and extendable shelves, can be used in selecting accessories for the cabinet.





Storage system

The Treston Group storage system can be built as a combination of cabinets and shelves and you can use it as a space divider. The storage system is available in two standard heights, 200 cm and 240 cm and two widths, 80 cm and 100 cm.

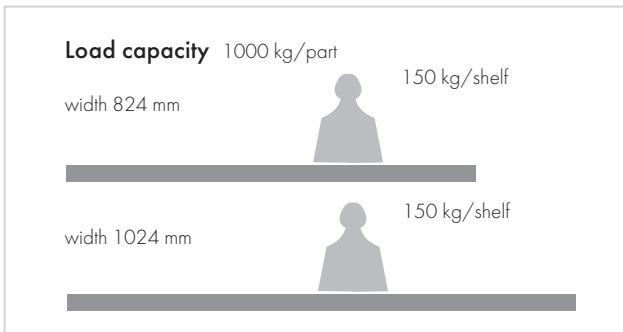

! The W x D x H rule
All our dimensions follow a WDH rule, where the first dimension is the width (W), the middle the depth (D), and the last the height (H).



1. Standard parts

Name	Size W x D x H mm	Code
Standard part 80/30/200	824 x 300 x 2000	C 313 35 001
Standard part 80/40/200	824 x 400 x 2000	C 314 35 001
Standard part 100/30/200	1024 x 300 x 2000	C 313 35 002
Standard part 100/40/200	1024 x 400 x 2000	C 314 35 003
Standard part 100/50/200	1024 x 500 x 2000	C 315 35 001
Standard part 100/60/200	1024 x 600 x 2000	C 316 35 001
Standard part 80/40/240	824 x 400 x 2400	C 314 35 002
Standard part 100/40/240	1024 x 400 x 2400	C 314 35 004
Standard part 100/50/240	1024 x 500 x 2400	C 315 35 002
Standard part 100/60/240	1024 x 600 x 2400	C 316 35 002

2. Extension parts

Name	Size W x D x H mm	Code
Extension part 80/30/200	804 x 300 x 2000	C 323 35 001
Extension part 80/40/200	804 x 400 x 2000	C 324 35 001
Extension part 100/30/200	1004 x 300 x 2000	C 323 35 002
Extension part 100/40/200	1004 x 400 x 2000	C 324 35 003
Extension part 100/50/200	1004 x 500 x 2000	C 325 35 001
Extension part 100/60/200	1004 x 600 x 2000	C 326 35 001
Extension part 80/40/240	804 x 400 x 2400	C 324 35 002
Extension part 100/40/240	1004 x 400 x 2400	C 324 35 004
Extension part 100/50/240	1004 x 500 x 2400	C 325 35 002
Extension part 100/60/240	1004 x 600 x 2400	C 326 35 002

All standard and extension parts include 6 shelves.

Storage cabinets

1. 100/40/200-1

C 344 07 001 (blue), C 344 35 001 (light grey)

Qty	Name	Size mm	Code blue	Code light grey
1	Storage cabinet	1024 x 400 x 2000	C 344 07 000	C 344 35 000
4	Shelf	1000 x 400	852 231-35	852 231-35

2. 100/40/200-4

C 344 07 004 (blue), C 344 35 004 (light grey)

Qty	Name	Size mm	Code blue	Code light grey
1	Storage cabinet	1024 x 400 x 2000	C 344 07 000	C 344 35 000
2	Shelf	1000 x 400	852 231-35	852 231-35
2	Perforated panel	983 x 500	852 145-07	852 145-35
3	Drawer 400		834 513-35	834 513-35

! Move with a pallet truck
The cabinet can be moved with a pallet truck or a forklift when the plinth front panel has been removed. Cabinets are equipped with adjustment screws.



The Treston Group storage system includes a wide range of different parts which can be used to create a fully tailor-made solution.

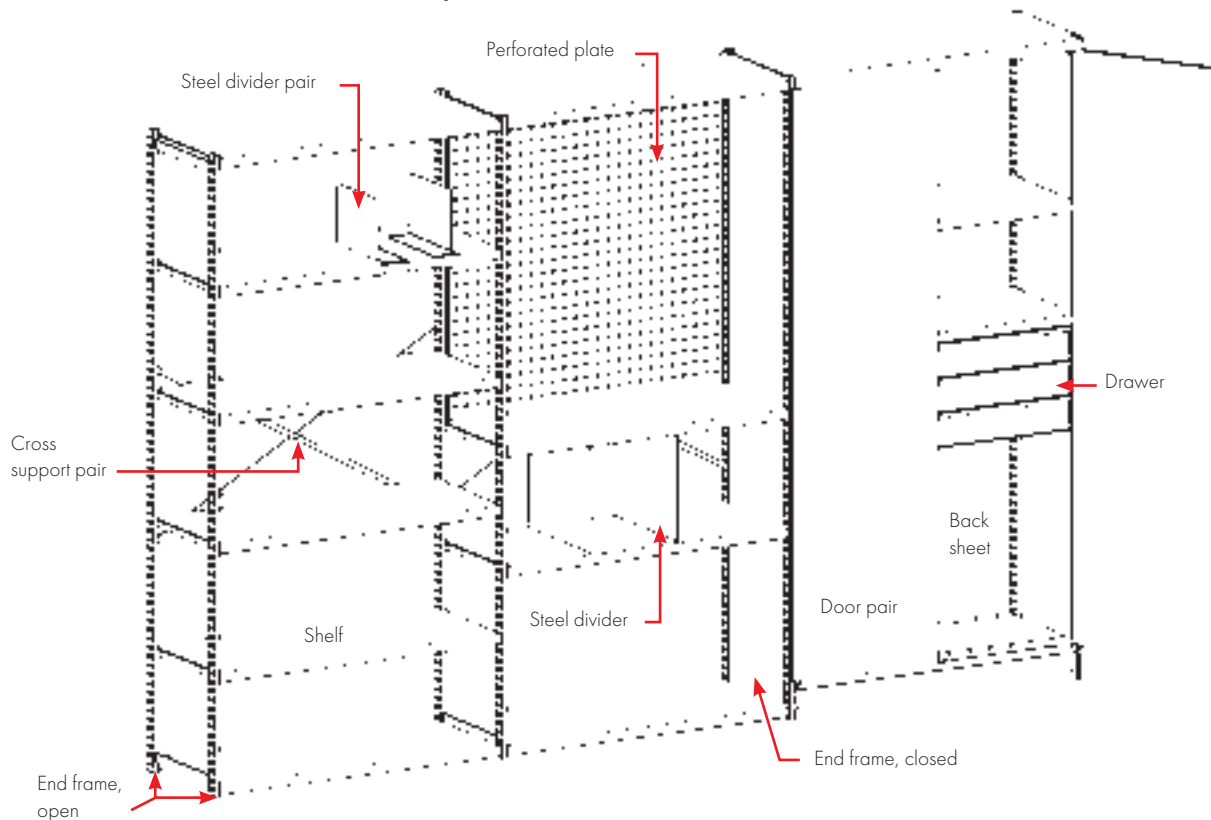

Storage system components

Name	Size W x D mm	Code
End frame, open	300 x 2000	830 615-35
End frame, open	400 x 2000	830 895-35
Sidewall	400 x 2000	859 440-35
End frame, open	500 x 2000	851 719-35
Sidewall	500 x 2000	859 450-35
End frame, open	600 x 2000	851 725-35
Sidewall	600 x 2000	859 460-35
End frame, open	400 x 2400	851 717-35
End frame, open	500 x 2400	851 721-35
End frame, open	600 x 2400	851 724-35
Cross support pair 1000		852 176-35
Cabinet 100/40/200	1030 x 430 x 2010	C 344 07 000
Cabinet 100/50/200	1030 x 530 x 2010	C 345 07 000
Cabinet 100/60/200	1030 x 630 x 2010	C 346 07 000
Back sheet 1000		859 447-35
Perforated end plate 400	340 x 2000	830 917-07
Screw set (fixing back to back)		838 440-51
Perforated panel 1000	983 x 500	852 145-07
Additional support for shelf 1000		852 267-35

Shelves

Name	Size W x D mm	Max load kg	Code
Shelf	800 x 300	150	852 235-35
Shelf	800 x 400	150	852 234-35
Shelf	1000 x 300	150	852 175-35
Shelf	1000 x 400	150	852 231-35
Shelf	1000 x 500	150	852 185-35
Shelf	1000 x 600	150	852 187-35

Shelf dividers

Name	Size W x D mm	Code
Pair of steel dividers	190 x 285	861 116-35
Shelf divider 400	400 x 180	832 839-35
Shelf divider 400	400 x 260	832 847-35
Shelf divider 400	400 x 370	832 855-35
Shelf divider 500	500 x 260	852 271-35
Shelf divider 500	500 x 370	852 273-35
Shelf divider 600	600 x 260	852 797-35
Shelf divider 600	600 x 370	852 798-35

Drawers and interior combinations

Name	Size W x D x H mm	Max load kg	Code
Drawer 100/100, for 400 deep cabinet	920 x 345 x 107	30	834 513-35
Drawer 100/100, for 500 deep cabinet	920 x 345 x 107	30	834 514-35
1 Middle divider and middle plates			834 507-35
2 Middle divider and middle plates			834 508-35
3 Middle divider and middle plates			834 509-35
4 Pick up bins			834 512-00

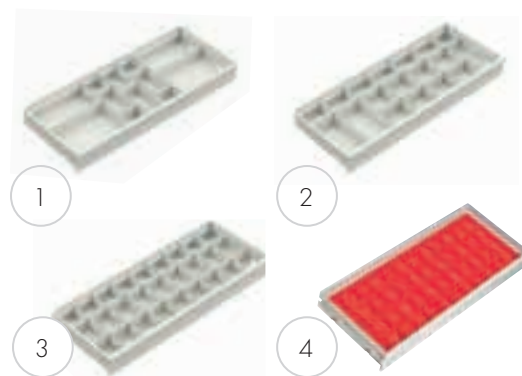



Industrial cabinets

A versatile storage solution can be created using the appropriate accessories. Treston Group industrial cabinets include a wide range of accessories e.g. for tool storage.



Industrial cabinet combinations



55/100-1 C 301 07 001

Qty	Name	Code
1	Cabinet frame 55/100	C 301 07 000
2	Steel shelf 55	854 349-35



80/100-1 C 305 07 001001

Qty	Name	Code
1	Cabinet frame 80/100	C 305 07 000
2	Steel shelf 80	854 345-35



80/100-2 C 305 07 002

Qty	Name	Code
1	Cabinet frame 80/100	C 305 07 000
2	Steel shelf 80	854 345-35
1	Drawer 80	854 346-35

Combination name

55/100-1

Width cm Height cm Version

Depth of cabinet: 425 mm



Practical!

100 cm high cabinets have a backstop and rubber mat to be used as an additional work top.





Computer cabinet

Computer cabinet protects equipment from dust and dirt, even in the most demanding conditions. The computer cabinet is pressurised and equipped with an air filter that keeps the dust out. A screen up to a maximum size of 19" will fit in the computer cabinet.



Computer cabinets

Name	Size W x D x H mm	Code
Computer cabinet	800 x 500 x 1600	854 358-35
Computer cabinet (without the energy rail)	800 x 500 x 1600	854 364-35



55/160-1 C 303 07 001

Qty	Name	Code
1	Cabinet frame 55/160	C 303 07 000
3	Steel shelf 55	854 349-35



80/160-1 C 307 07 001

Qty	Name	Code
1	Cabinet frame 80/160	C 307 07 000
3	Steel shelf 80	854 345-35



80/160-2 C 307 07 102

Qty	Name	Code
1	Cabinet frame 80/160	C 307 07 000
2	Steel shelf 80	854 345-35
4	Bin rail, M750	859 151-35
21	Stacking bin	1015-5
5	Stacking bin	1525-5



80/160-3 C 307 07 003

Qty	Name	Code
1	Cabinet frame 80/160	C 307 07 004
3	Steel shelf 80	854 345-35
1	Extendable shelf 80	854 347-35



Move with a pallet truck

The cabinet can be moved with a pallet truck or a forklift when the plinth front panel has been removed. Cabinets are equipped with adjustment screws.



80/200-1 C 309 07 001

Qty	Name	Code
1	Cabinet frame 80/200	C 309 07 000
4	Steel shelf 80	854 345-35



80/200-2 C 309 07 102

Qty	Name	Code
1	Cabinet frame 80/200	C 309 07 000
2	Drawer 80	854 346-35
2	Steel shelf 80	854 345-35
5	Stacking bin	1525-5
1	Bin rail, M750	859 151-35
1	Extendable shelf 80	854 347-35
1	Perforated panel 736 x 640	835 633-07
2	Perforated panel 288 x 712	854 353-07
1	Pair of support feet	864 730-35



80/200-3 C 309 07 103

Qty	Name	Code
1	Cabinet frame 80/200	C 309 07 000
2	Drawer 80	854 346-35
2	Steel shelf 80	854 345-35
3	Shelf divider H 370/400	832 855-35
1	Perforated panel 736 x 640	835 633-07
1	Extendable shelf 80	854 347-35
1	Pair of support feet	864 730-35
1	Pair of steel dividers	861 116-35
1	Drawer for suspension folders	854 348-35



80/200-4 C 309 07 004

Includes 2 pcs steel shelves 80 , 854 345-35.



An extendable shelf for the cabinet

When the cabinet is used for storing folders, a separate extending shelf is a good idea. This shelf makes it easy to browse through the folders.



Industrial cabinet accessories



All the M750 accessories fit the cabinet 80 and can be easily installed inside.

Cabinet frames

Name	Size W x D x H mm	Code
Cabinet 55/100 •	550 x 425 x 1000	C 301 07 000
Cabinet 80/100	800 x 425 x 1000	C 305 07 000
Cabinet 55/160	550 x 425 x 1600	C 303 07 000
Cabinet 80/160	800 x 425 x 1600	C 307 07 000
Cabinet 80/160, half doors	800 x 425 x 1600	C 307 07 004
Cabinet 80/200	800 x 425 x 2000	C 309 07 000

Cabinet accessories

Name	Size W x D x H mm	Max load kg	Code
Perforated panel for the door or side wall	280 x 740		854 353-07
Perforated panel for the back wall M500	487 x 295		860 951-35
Perforated panel for the back wall M750	736 x 640		835 633-35
Perforated panel for the back wall M750	718 x 1003		835 641-35
Pair of steel dividers	1 x 285 x 190		861 116-35
Steel shelf 55	545 x 391 x 32	100	854 349-35
Steel shelf 80	730 x 396 x 32	100	854 345-35
Shelf divider	1 x 400 x 180		832 839-35
Shelf divider	1 x 400 x 260		832 847-35
Shelf divider	1 x 400 x 370		832 855-35
Extendable shelf 80	730 x 362 x 42	30	854 347-35
Drawer 55 •	480 x 362 x 90	30	854 344-35
Drawer 80	730 x 362 x 90	30	854 346-35
Drawer for suspension folders	724 x 350 x 240	30	854 348-35
Pair of support feet	40 x 220 x 6		864 730-35
Bin rails M750	742 x 100	50	859 151-35

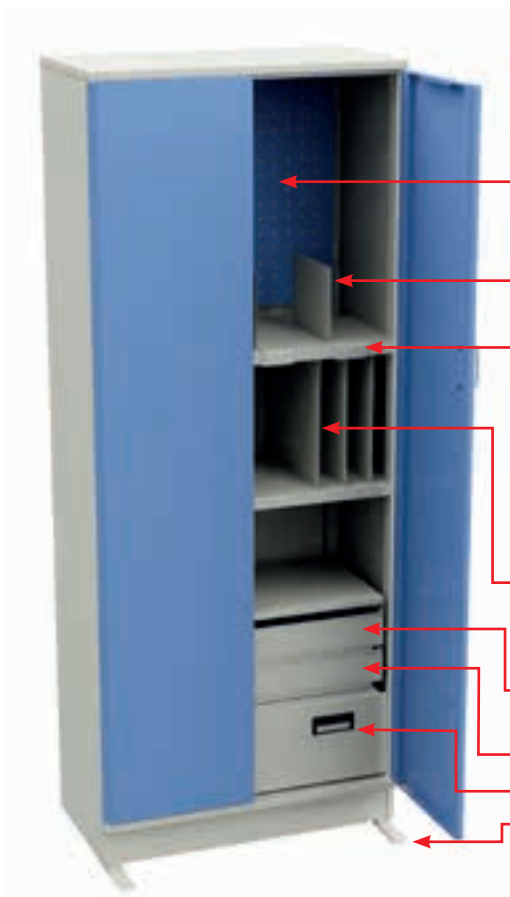

Spare parts for industrial cabinets

Cabinet spare parts

Name	Product	Code
Rubber mat 550 x 420	Industrial cabinet 55/100	836 716-00
Rubber mat 799 x 420	Industrial cabinet 80/100	836 715-00

• = non stock item



Shelf cabinets

High-quality shelf cabinet is made of semiconductive epoxy powder coated, profiled steel, light grey RAL 7038. Standard fittings: cabinet lock with two keys, sturdy double leaf-doors, 2 or 4 shelves, adjustable feet and cabinet base of steel. The robust base is welded together. The cabinet unit can be moved with a pallet truck or a forklift when the plinth front plate has been removed. This cabinet is pre-assembled.

Shelf cabinets

Name	Shelves number	Size W x D x H mm	Max load kg / shelf	Code ESD
Shelf cabinet	2	800 x 425 x 1000	100	C 305 35 001
Shelf cabinet	4	800 x 425 x 2000	100	C 309 35 001

Shelf cabinet accessories

Name	Size W x D x H mm	Max load kg	Code ESD
Steel shelf 80	730 x 396 x 32	100	854 345-35
Perforated panel	736 x 640		835 633-35
Drawer 80	730 x 362 x 90 (outer)	30	854 346-35



More accessories on page 93

Industrial cabinet accessories suit also shelf cabinets.

Light shelf cabinets

Designed for use in light storage. This cabinet is flat packed in an individual carton with all necessary fittings and instructions. Steel cabinets are epoxy powder coated in light grey. The shelves can be adjusted on 50 mm centres. Standard fittings: Locking bar system, steel double doors, 2 or 3 shelves and cabinet base.



Light shelf cabinets

Name	Shelves number	Size W x D x H mm	Max load kg / shelf	Code ESD
Shelf cabinet	2	915 x 460 x 1015	50	HK100 ESD
Shelf cabinet	3	915 x 460 x 1830	50	HK180 ESD

Shelf cabinet accessories

Name	Size W x D mm	Max load kg	Code	Code ESD
Extra shelf	910 x 385	-		H49 K ESD
Perforated panel	880 x 550		RLHK49	RLHK49 ESD



Small parts shelving



Shelving unit



Extension unit

An ESD protected, effective storage system. Shelving unit includes 6 adjustable shelves. Small parts shelving with accessories are of semiconductive epoxy powder coated steel in light grey RAL 7035. Earth via protective 1 megohm resistor. Height 2020 mm, length 1040 mm. Extension unit includes 6 adjustable shelves.

Small parts storage shelving

Name	Size W x D x H mm	Max load kg / one shelf	Code ESD
Shelving unit	1040 x 410 x 2020	150	PH410 ESD
Shelving unit	1040 x 510 x 2020	200	PH510 ESD
Shelving unit	1040 x 610 x 2020	200	PH610 ESD
Extension unit	1020 x 410 x 2020	150	PH410L ESD
Extension unit	1020 x 510 x 2020	200	PH510L ESD
Extension unit	1020 x 610 x 2020	200	PH610L ESD

Accessories

Name	Size W x D mm	Max load kg / one shelf	Code ESD
Extra shelf	1000 x 400	150	H410 ESD
Extra shelf	1000 x 500	200	H510 ESD
Extra shelf	1000 x 600	200	H610 ESD
Dividing panel •	335 x 2015		VS4 ESD
Dividing panel •	435 x 2015		VS5 ESD
Dividing panel •	535 x 2015		VS6 ESD
Side panel •	400 x 2015		PS4 ESD
Side panel •	500 x 2015		PS5 ESD
Side panel •	600 x 2015		PS6 ESD
Back panel •	1000 x 1920		TS10 ESD

• = non stock item



Industrial screens





Industrial screens work as noise insulators and space dividers

The compact and modern Treston Group industrial office screen system with panel and accessory options can be used almost anywhere; from production facilities to offices. Noise from production areas or loud voices from neighbouring workstations are often disturbing factors. One way of reducing the noise level is to divide workspaces from each other and/or separate them from production areas. This can be easily done with Treston Group screens. An individual workstation aids concentration and improves accuracy. With Treston Group screens noise levels can be reduced on average, by 7-9 dB to the standard ISO 10053 (VTT Research Centre Finland).

Divider screen panels can be used individually, in straight lines, or at right angles to form enclosed spaces. Create a uniform, stylish look with screens throughout your company!

An anodized aluminium frame holds panels made of blue or grey fabric panelling or perforated panel



Industrial office screen system

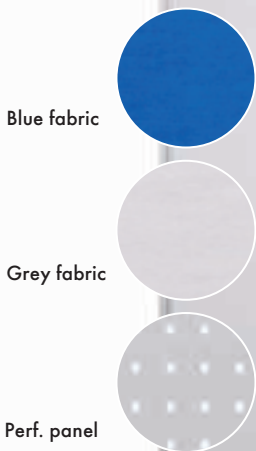

Screen panels

Name	Material	Size L x H mm	Code	Code ESD
Screen panel	Blue fabric	750 x 1245	P0712 FB	P0712 FB ESD
Screen panel	Blue fabric	750 x 2000	P0720 FB	P0720 FB ESD
Screen panel	Blue fabric	1050 x 1245	P1012 FB	P1012 FB ESD
Screen panel	Blue fabric	1050 x 2000	P1020 FB	P1020 FB ESD
Screen panel	Grey fabric	750 x 1245	P0712 FG	P0712 FG ESD
Screen panel	Grey fabric	750 x 2000	P0720 FG	P0720 FG ESD
Screen panel	Grey fabric	1050 x 1245	P1012 FG	P1012 FG ESD
Screen panel	Grey fabric	1050 x 2000	P1020 FG	P1020 FG ESD
Screen panel	Perf. panel*	750 x 1245	P0712 S	P0712 S
Screen panel	Perf. panel*	750 x 2000	P0720 S	P0720 S
Screen panel	Perf. panel*	1050 x 1245	P1012 S	P1012 S
Screen panel	Perf. panel*	1050 x 2000	P1020 S	P1020 S

Legs are ordered separately.

* light grey RAL 7035, 9 mm perforations at 38 mm centres.

Suitability of legs (ordered separately, 1 pc per pack)

Panel size	Code T-leg 400	Code T-leg 600	Code L-leg 250	Code Corner leg set
750 x 1245	TLEG400	-	LLEG250	CLEG
750 x 2000	TLEG400*	TLEG600	LLEG250*	CLEG
1050 x 1245	TLEG400	-	LLEG250	CLEG
1050 x 2000	TLEG400*	TLEG600	LLEG250*	CLEG

* We recommend this leg for the low panels but it can be mounted to high fabric panels and all corner layouts.

- TLEG 400 is suitable for all low panels, and high fabric panels. Complete assembly's height:
1275 - 1315 mm (low panels)
2030 - 2070 mm (high panels)
- TLEG 600 is suitable for all high panels, fabric and steel. Adjustable feet are provided for fine levelling. Complete assembly's height: 2070 - 2080 mm.
- CLEG- corner leg set for all panels. Can be used with two panels to create a 90 deg corner.
- LLEG 250 is suitable for all low panels, and high fabric panels. Complete assembly's height:
1275 - 1315 mm (low panels)
2030 - 2070 mm (high panels)
- One screen panel will need a panel and two legs, which are ordered separately.
- Straight line assemblies require two legs for the first panel and one leg for each additional panel.



T-leg 400



T-leg 600



L-leg 250



Corner leg set



1

No. 1 Combination includes

- 6 pcs acoustic panel P1012 FB, 1050 x 1245 mm
- 6 pcs leg TLEG 400
- 1 pcs corner leg GLEG
- 2 pcs workbench WB811, 800 x 1073 mm
- 1 pc corner worktop WB1212 CT, 1153 x 1153 mm
- 1 pc aluminium profile AL2X110
- 1 pc adjustable shelf ASH110, 400 x 960 mm
- 1 pc support bracket HSB110
- 1 pc lighting unit OL254
- 1 pc cable channel CJK100 SET
- 1 pc chair X40L R

No. 2 Combination includes

- 2 pcs acoustic panel P1012 FG, 1050 x 1245 mm
- 3 pcs leg TLEG 400
- 3 pcs bin rail PBP100 ESD

No. 3 Combination includes

- 4 pcs perforated steel panel P0720 S, 750 x 2000 mm
- 5 pcs leg TLEG 600
- 1 pc bin rail PBP100 ESD

No. 4 Combination includes

- 4 pcs acoustic panel P1012 FB, 1050 x 1245 mm
- 4 pcs leg TLEG 400
- 1 pc corner leg GLEG
- 2 pcs steel shelf PSS100 ESD



2



3

Bin rail PBP

Aluminium rail for stacking bins 1015, 1520, 1525 and 1930. Load capacity 10 kg. Aluminium profile/semiconductive epoxy powder coated steel. Max 3 profiles/one side.



4

Steel shelf PSS

Steel semiconductive epoxy powder coated shelf. The shelf can sit on the brackets as normal or hang from the brackets to provide end stops. Load capacity 10 kg. Max. 3 shelves/one side.



Bin rail PBP



Steel shelf PSS

Power channel PJK

May be fitted with a choice of components, ordered separately. All meet with CE requirements. 3 m cable is included. Supplied wired and ready for use.

Industrial screen accessories

Name	Size mm	Code ESD
Bin rail	700	PBP70 ESD
Bin rail	1000	PBP100 ESD
Steel shelf	170 x 710	PSS70 ESD
Steel shelf	170 x 1010	PSS100 ESD
Power channel	640	PJK70
Power channel	940	PJK100



Power channel PJK

****COMPONENTS FOR POWER CHANNEL PJK**

- E1 Double socket
- E2 Switch
- E3 Automatic fuse 10 A
- E4 Automatic fuse/earth leakage switch 10 A/30 mA
- E5 Emergency-stop-switch
- E6 Data connector/shielded for Cat.6 cable
- E7 Data connector for Cat.5 cable
- E8 Pneumatic, quick coupling 3/8" Cat 5



Perforated industrial screens

These industrial screens are modular, and they can be equipped with all M750 accessories. Industrial screens can be used as space dividers. They also provide noise insulation; the combinations available have perforated back panels on both sides and one side is insulated.

Industrial screens

Name	Size W x D x H mm	Code
Standard part, T-feet	780 x 60 x 1850	C 520 07 101
Extension part, T-foot	750 x 560 x 1850	C 520 07 102
Extension part, L-foot	750 x 310 x 1850	C 520 07 103
Extension part, I-foot	750 x 60 x 1850	C 520 07 104

Includes 6 perforated back panels, 3 pcs./side.

The standard part includes two feet.

The extension part includes one foot.

Parts

Name	Size W x D x H mm	Code
T-foot	1850	836 516-35
L-foot	1850	836 532-35
I-foot	1850	836 597-35
Spacer bar	750	835 838-35
Corner joint pair		847 615-51
Perforated back panel M750	718 x 17 x 612	861 512-07/-35
Perforated back panel M750, insulated*	718 x 17 x 612	861 701-07/-35
Upper list	718 x 65	851 907-07

The wall module requires two spacer bars.

* The insulation material used is polyether foam.

All M750 accessories are suitable for the industrial screen.

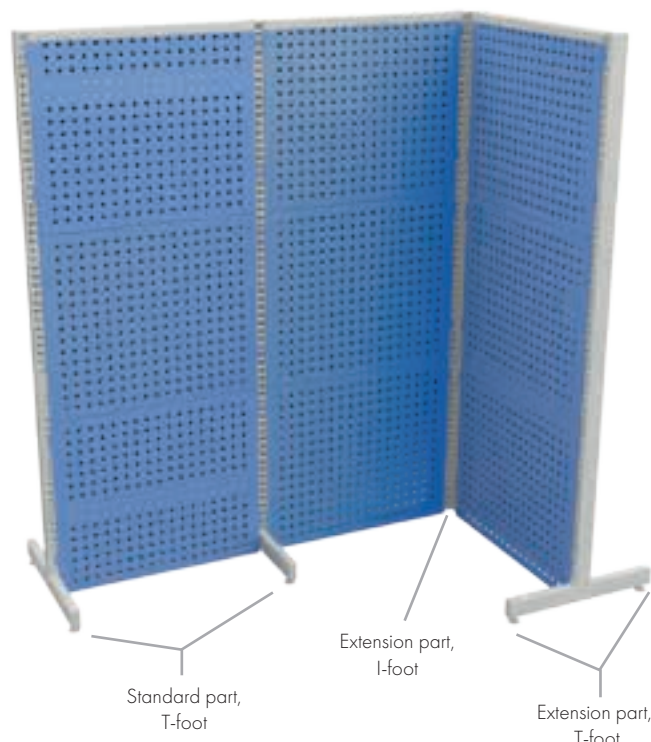

The colour code is included in those product codes that are formed with numbers.

It is either at the end, following the hyphen (e.g. 860 804-35), or in the middle (e.g. C 334-07-000).

Industrial screen accessories

Name	Size W x D mm	Max load kg	Code
Steel shelf M750	740 x 300	50	836 028-35
Steel shelf M750	740 x 400	50	852 770-35
Bin rail M750	742 x 100	50	859 151-35



More accessories starting from page 33

M750 accessories suit these industrial screens.



Steel shelf



Bin rail M750 with brackets and stacking bins.



Perforated panels





Perforated panels are a part of a good organisation

Perforated panels are efficient dividers of space and, at the same time, practical storage facilities for tools and equipment. An industrial screen can be used as a sound-insulating space divider by equipping it with back panel elements with fireproof insulation.

Order and tidiness are appreciated

Order and tidiness cannot be achieved and maintained without there being a place for each tool. Perforated

panels and hooks offer a practical and versatile solution for storing tools and equipment. Perforated panel products are available for direct fastening to the wall or for fastening to upright profiles or tubes.

Hooks also for heavy loads

The hooks can withstand loads of up to 20 kg.





Perforated panels

The perforated back panels are fastened either to the upright tubes (with Concept and TP benches) or accessory frame AKK (with WB bench). The size of the perforation is 9 x 9 mm, center to center 38 mm.

1. Perforated panels for concept and TP benches

Name	Module	Size W x H mm	Code ESD
Perforated back panel	M500	468 x 389	861 501-35
Perforated back panel	M750	718 x 194	861 510-35
Perforated back panel	M750	718 x 389	861 511-35
Perforated back panel	M750	718 x 612	861 512-35
Perforated back panel, insulated	M750	718 x 612	861 701-35
Perforated back panel	M750	718 x 1003	861 514-35
Perforated back panel	M900	871 x 389	861 516-35
Perforated back panel •	M1350	1318 x 389	861 521-35
Perforated back panel •	M1500	1474 x 389	861 526-35
Perforated back panel •	M1800	1774 x 389	861 531-35

Fastened to the upright tubes (see pages 30 & 44).

2. Back panels for concept and TP benches

Name	Module	Size W x H mm	Code ESD
Back panel •	M500	468 x 389	861 541-35
Back panel	M750	718 x 194	861 550-35
Back panel	M750	718 x 389	861 551-35
Back panel	M750	718 x 612	861 552-35
Back panel	M900	871 x 389	861 556-35

Fastened to the upright tubes (see pages 30 & 44).

3. Perforated panels for TPH benches

Size W x H mm	Suitable for	Code	Code ESD
1115 x 750	TPH712	RL120	RL120
1415 x 750	TPH715/ 915	RL150	RL150
1715 x 750	TPH718/ 918	RL180	RL180
Panel hooks	TPH	RK1	RK1

Mount on TPH benches with panel hooks RK1. Can also be attached to a wall with screws (included).



4. Perforated panels for WB benches

Size W x H mm	Suitable for	Code ESD
668 x 500	AKK70, AKK150	ARL70
968 x 500	AKK180	ARL100

Mount on accessory frame AKK (see page 22).





Panel hooks

Our selection includes more than 50 different kinds of hooks and brackets for the efficient storage and organisation of

tools. All the hooks and brackets can be easily attached to our perforated panels.



Hook R1

Name	L	Ø	Max load kg	Code
Hook R1	30	3	10	853 207-51
Hook R1	50	4	10	853 208-51
Hook R1	50	6	10	853 241-51
Hook R1	80	6	10	853 209-51
Hook R1	100	4	8	853 210-51
Hook R1	100	6	10	853 211-51
Hook R1	150	4	4	853 212-51
Hook R1	150	6	10	853 213-51
Hook R1	200	4	2	853 214-51
Hook R1	200	6	6	853 215-51
Hook R1	300	6	3	853 216-51
Hook R1	300	8	8	853 217-51

L = hook length mm

All order numbers include 5 pcs.

Hook R2

Name	L	Ø	A	Max load kg	Code
Hook R2	33	3	17	10	853 218-51
Hook R2	43	4	25	10	853 219-51
Hook R2	43	4	40	10	853 220-51
Hook R2	100	6	25	10	853 221-51
Hook R2	150	4	15	6	853 222-51
Hook R2	150	6	25	10	853 223-51
Hook R2	200	6	25	10	853 224-51

L = hook length mm

A = free gap mm

All order numbers include 5 pcs.

Hook R3

Name	L	Ø	Max load kg	Code
Hook R3	10	6	10	853 225-51
Hook R3	50	6	10	853 226-51

L = hook length mm

All order numbers include 5 pcs.

Hook R10

Name	L	A	Max load kg	Code
Hook R10	28	9	10	853 227-51
Hook R10	33	17	10	853 228-51

L = hook length mm

A = free gap mm

All order numbers include 5 pcs.

Hook R13

Name	L	Ø	Max load kg	Code
Hook R13	157	3	1	853 229-51

L = hook length mm

The order number includes 5 pcs.

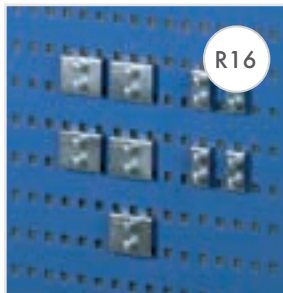

R16

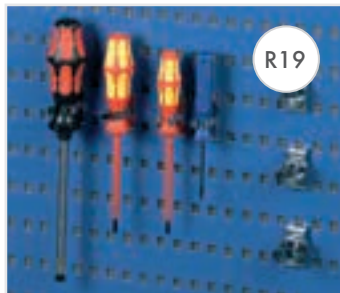

R19

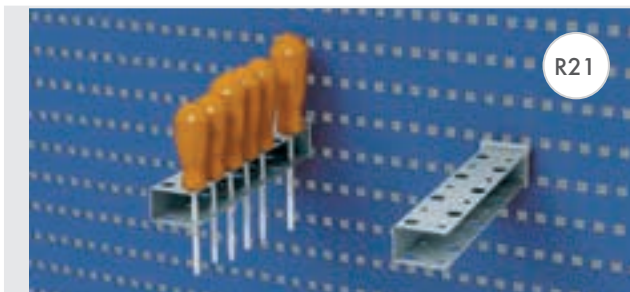

R21



R24



R26



R29



R30



R33

Hook R16

Name	L	Max load kg	Code
Hook R16	20	10	831 514-51
Hook R16	46	10	831 506-51

L = hook length mm

All order numbers include 1 pc.

Hook R19

Name	Ø	Code
Hook R19	13	853 231-51
Hook R19	19	853 232-51
Hook R19	22	853 233-51

All order numbers include 5 pc.

Hook R21

Name	L	Ø	Code
Hook R21	220	12	831 646-51

L = hook length mm

The order number includes 1 pc.

Hook R24

Name	L	Ø	Code
Hook R24	65	17	831 700-51
Hook R24	80	26	831 719-51
Hook R24	100	42	852 167-51

L = hook length mm

All order numbers include 1 pc.

Hook R26

Name	L	Ø	Code
Hook R26	160	10	838 896-51

L = hook length mm

The order number includes 1 pc.

Hook R29

Name	L	Max load kg	Code
Hook R29	40	5	853 234-51
Hook R29	60	5	853 235-51
Hook R29	80	10	853 236-51

L = hook length mm

All order numbers include 5 pcs.

Hook R30

Name	L	Ø	Max load kg	Code
Hook R30	35	4	10	853 237-51
Hook R30	85	6	10	853 238-51

L = hook length mm

All order numbers include 5 pcs.

Hook R33

Name	H	Ø	Code
Hook R33	30	90	832 162-51

H = hook height mm

The order number includes 1 pc.



R35



R37



R41



R42

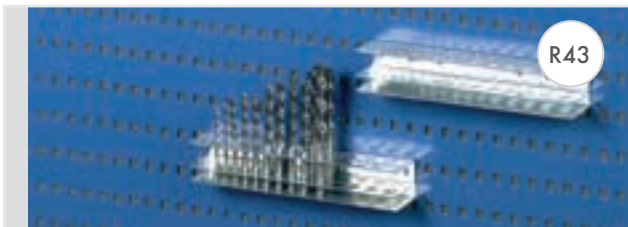

R43

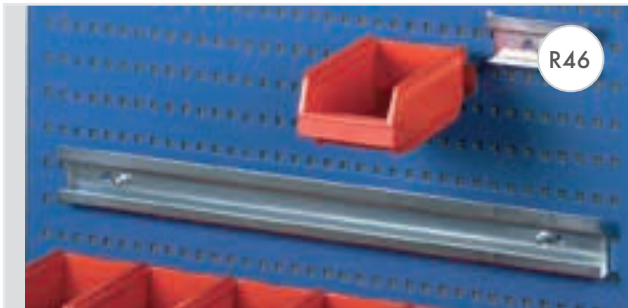

R46



R47



R48

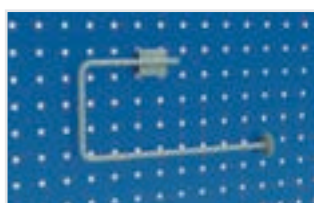

Hook R35

Name	L	A	Code
Hook R35	17	35	853 239-51
Hook R35	17	55	853 240-51

L = hook length mm

A = free gap mm

All order numbers include 5 pcs.

Hook R37

Name	∅	Max load kg	Code
Hook R37	40	10	831 433-51
Hook R37	60	10	831 441-51
Hook R37	80	10	831 603-51

All order numbers include 1 pc.

Hook R41

Name	L	Code
Hook R41	556	838 357-51

L = hook length mm

The order number includes 1 pc.

Hook R42

Name	L	Code
Hook R42	238	838 365-51

L = hook length mm

The order number includes 1 pc.

Hook R43

Name	L	Code
Hook R43	238	838 373-51

L = hook length mm

The order number includes 1 pc.

Hook R46

Name	L	Code	
Hook R46	112	for stacking bins 1015 and 30-1L	831 794-51
Hook R46	634	bin rail for six stacking bins 1015 and 30-1L	839 086-51

L = hook length mm

All order numbers include 1 pc.

Hook R47

Name	W x D	Max load kg	Code
Hook R47	350 x 120	4	831 654-35

The order number includes 1 pc.

Hook R48

Name	W x D x H	Code
Hook R48	240 x 70 x 465	838 380-51

The order number includes 1 pc.

Paper roll holder

Name	L	Code
Paper roll holder	300	854 043-35

L = max roll width mm

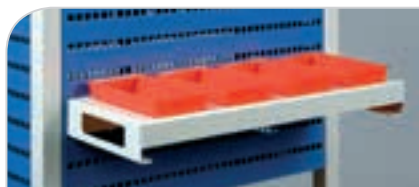

Box holder

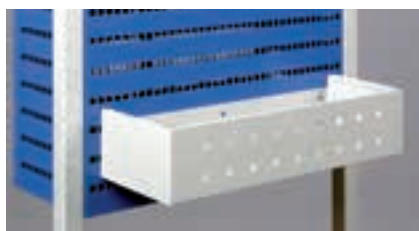

Utility box

Other supplies

Name	Size W x D x H mm	Max load kg	Code
Box holder for four pick up boxes	456 x 165 x 48	5	854 042-35
Utility box	410 x 155 x 90	4	854 041-35
Folder compartment	466 x 90 x 240	4	854 040-35



Folder compartment

Hook sets

Ready-made hook sets help you to get started.

Choose the most suitable hook set for your needs from the following possibilities:

- Hook set 1 Basic light hook set
- Hook set 2 Basic hook set for hand tools
- Hook set 3 Hook set for perforated tool cabinet
- Hook set 4 All inclusive set for hand tools
- Hook set 5 Hook set for heavy tools in perforated tool cabinet



Hook sets

Hooks included in the sets (Code)	Hooks sets							
	L mm	Ø mm	A mm	Set 1 855 001-51	Set 2 855 002-51	Set 3 855 003-51	Set 4 855 004-51	Set 5 855 005-51
R1 (853 207-51)	30	3			5	15	10	10
R1 (853 208-51)	50	4		5	5		10	10
R1 (853 211-51)	100	6						10
R2 (853 218-51)	33	3	17	5	5	5	5	5
R2 (853 219-51)	43	4	25				5	5
R2 (853 220-51)	43	4	40					5
R10 (853 227-51)	28		9					5
R10 (853 228-51)	33		17					5
R19 (853 231-51)		13					5	5
R19 (853 232-51)		19		5	5	5	5	5
R19 (853 233-51)		22			5			5
R21 (831 646-51)	220	12			1			1
R24 (831 719-51)	80	26			1	5	7	3
R24 (852 167-51)	100	42				1	2	3
R29 (853 235-51)	60				5			5
R30 (853 237-51)	35	4		5	5	35	40	10
R33 (832 162-51)	30	90			1	1	2	1
R35 (853 239-51)	17		35		5		5	5
R35 (853 240-51)	17		55					5
R37 (831 441-51)		60			1		3	3
R42 (838 365-51)	35		238		1	1	1	1
R43 (838 373-51)	42		238			1		
Pieces				20	45	69	100	107

L = hook length mm
A = free gap mm

Drawer unit spare parts

Name	Compatibility	Code
Cover with rubber mat, ESD	45 drawer unit	872 242-35
Shelf for cabinet version	45 drawer unit	872 043-35
Bracket pair for the shelf	45 and 75 drawer units	872 045-51
Cover with rubber mat, ESD	75 drawer unit	872 243-35
Shelf for cabinet version	75 drawer unit	872 044-35
Castor set Ø 100 ESD	45 and 75 drawer units	852 774-00

Drawer interior spare parts

Name	Compatibility	Code
Divider H=100, lateral	45/100 drawer	872 950-35
Divider H=100, lateral	75/100 drawer	872 952-35
Divider H=150, lateral	45/150 drawer	872 951-35
Divider H=150, lateral	75/150 and 200 drawers	872 953-35
Divider holder, side wall	45 and 75 drawers	872 960-35
Divider H=100, longitudinal	75/100 drawer	872 954-35
Divider H=150, longitudinal	75/150 drawer	872 955-35
Divider holder, rear wall	75 drawer	872 961-35

Spare parts for industrial cabinets

Name	Compatibility	Code
Rubber mat 550 x 420	Industrial cabinet 55/100	836 716-00
Rubber mat 799 x 420	Industrial cabinet 80/100	836 715-00

Castors

Name	Compatibility	Code
Castor set Ø 100 ESD	45 and 75 drawer units	852 774-00
Castor set Ø 100	Worktop trolley, Storage trolley, Ergo trolley	852 768-00
Castor set Ø 100	Concept and TP benches	834 734-00
Castor set Ø 125	Basic trolley	834 740-00
Castor set Ø 100 ESD	Worktop trolley, Storage trolley, Ergo trolley	852 774-00
Castor set Ø 100 ESD	Multi trolley, Concept and TP benches	860 429-00
Castor set Ø 50	Transport skate	853 176-00
Castor set Ø 50 ESD	Transport skate ESD	853 175-00

Spare parts for chairs

Name	Height adjust mm	Dimension mm	Compatibility	Code	Code ESD
Arm rests X-series	140-220		X-series	AR	
Arm rests X-series ESD	140-220		X-series, ESD		AR ESD
Arm rests, task chair S	160-220		Task chair S	862 007-00	
Arm rests ESD, task chair S	160-220		Task chair S, ESD		862 006-00
Gas lift	400-540/410-550/420-560		X20 PU/X30/X40	4046	
Gas lift	450-650		X32	4062	
Gas lift	500-740		X35/X25 PU	4047	
Gas lift	370-510		X10	4047	
Gas lift, black	530-720		Task chair S	862 008-00	
Gas lift, ESD, chrome	530-720		Task chair S, ESD		862 009-00
Foot ring, chrome			X35, X25PU	8766	
Foot ring, chrome		Ø 440	Task chair S	831 190-50	
Black - swivelling twin castor for soft floors (brake unloaded), standard in X10 - X30		Ø 50	all chairs	4044	
Black/grey - SOFT swivelling twin castor for hard floors (brake unloaded), standard in X40		Ø 50	all chairs	4061	
Black - ESD swivelling twin castor for ESD floors (brake unloaded), standard in X10 - X40 ESD		Ø 50	all chairs		4045
Black/grey - ESD SOFT swivelling twin castor for ESD floors (brake unloaded), TO ORDER		Ø 50	all chairs		9692
Black/grey - ESD SOFT swivelling twin castor for ESD floors (brake loaded), TO ORDER		Ø 50	all chairs		9722
Crome swivelling twin castor for soft floor (brake loaded), TO ORDER		Ø 50	all chairs	9723	
Floor glide, standard in X25 PU, X35		Ø 14/50 mm, h: 39,5		4043	4060
High ESD floor glide, TO ORDER		Ø 36/50 mm, h: 59,5	X10, X20, X30		4088

Discover our product ranges!



Distinctive Workshops

Our workshop drawer cabinets, tool panels and workbenches are designed to withstand heavy loads and strenuous use in workshops, repair shops and industrial environments.

The long lifetime of our furniture guarantees productivity and a satisfied user. Our workshop furniture is also well known in teaching environments.



Ergonomic Workspaces

Process changes in production or operations require reconfigurable workstations that take account of individual ergonomics requirements. Our modular product solutions allow you to react to new situations and the resulting needs in an agile manner, enabling smooth, continuous operations.

For the needs of the electronics industry, we also make ESD-shielded workstations.



Storage systems

Our plastic storage drawers are durable and easy to clean, and can be customised into a complete storage system if necessary. Our product range also includes various stand and trolley solutions, for the more efficient use of storage space and easier movement of stored goods.

We also have storage furniture for EPAs. In addition, some of our storage solutions are based on reprocessed plastic.



Treston Medi

The Treston Medi furniture series has been designed in close cooperation with healthcare experts, resulting in user-friendly furniture for nursing staff. Our furniture includes various treatment and sampling trolleys for procedures, basket trolleys for moving, transporting and storing objects and implements, mobile workstations for mobile work such as doctor's rounds, equipment trolleys for diagnostics equipment, workstations for equipment maintenance rooms, and saddle and workchairs.

CONTACT INFORMATION

HEADQUARTERS

Treston Group
Sorakatu 1
20730 Turku
Tel. +358 10 4469 11
Fax +358 10 4469 789
sales@trestongroup.com
www.trestongroup.com

FACTORIES - FINLAND

Treston Group, Turku plant
Sorakatu 1
20730 Turku
Tel. +358 10 4469 11
Fax +358 10 4469 789
sales@trestongroup.com
www.trestongroup.fi

Treston Group, Jyväskylä plant
PO Box 33
40351 Jyväskylä
Tel. +358 10 4469 11
Fax +358 10 4469 290
sales@trestongroup.com
www.trestongroup.fi

FACTORY - GERMANY

Treston Deutschland GmbH
Profiltechnik
Sülkampweg 20
32278 Kirchlingern
Tel. +49 5223 18 02 70
Fax +49 5223 18 02 72
profiltechnik@trestongroup.com
www.trestongroup.de

FRANCE

Sovella SARL
Z.A.C. de la Bonne Rencontre
1, voie Gallo Romaine, Quincy-Voisins
77334 Meaux Cedex
Tel. +33 1 64 17 11 11
Fax +33 1 64 17 11 10
infofr@trestongroup.com
www.trestongroup.fr

GERMANY

Treston Deutschland GmbH
Thomas-Mann-Str. 21
22175 Hamburg
Tel. +49 40 8816 5022 - 0
Fax +49 40 8816 5022 - 10
info.de@trestongroup.com
www.trestongroup.de

Treston Deutschland GmbH
Niederlassung Raunheim
Frankfurter Straße 101
65479 Raunheim
Tel. +49 6142 992 50
Fax +49 6142 218 75
mail.de@trestongroup.com
www.trestongroup.de

RUSSIA

Treston Group Russia LLC
197375, Russia, Saint-Petersburg,
Marshala Novikova street 42
Tel. +7 812 677 76 20
www.trestongroup.com

SWEDEN

Treston Group AB
Tumstocksvägen 9 A
187 66 Täby
Tel. +46 8 511 791 60
Fax +46 8 511 797 60
info.se@trestongroup.com
www.trestongroup.se

Treston Group AB
Bultgatan 40
442 40 Kungälv
Tel. +46 31 23 33 05
Fax +46 31 23 33 65
info.se@trestongroup.com
www.trestongroup.se

UNITED KINGDOM

Treston Ltd
Treston House
5b Bone Lane, Newbury
Berkshire, RG14 5SH
Tel. +44 1635 521521
Fax +44 1635 37452
salesuk@trestongroup.com
www.trestongroup.co.uk

USA

Sovella, Inc.
156 Bluffs Court
Canton, GA 30114
Tel. +1 770 424 0004
+1 800 437 6772
Fax +1 770 424 8066
infousa@sovella.com
www.sovella.us

Long story in short



Treston Group has a long history in professional furniture design and manufacture, and well over three decades of experience in ergonomic workspace development. Our design and manufacturing facilities are located in Finland and Germany.

Thanks to our global sales network, you can receive local support and customer service anywhere in the world. We have offices in Europe and North America as well as an extensive network of selected dealers in more than 30 countries.